

# ITT

BCPELSPKT

Wastewater

## CentriPro Elevator Sump Kits and Components



A1SEEWATER  
Oil Smart  
Switch



S120ENPR Environment  
Protector Panel



A4-SEE1



3885

The Oil Smart Switch with panel or alarm, when combined with a pump, allows water to be pumped from Elevator sumps, leachate wells and transformer vaults without danger of pumping oil into sewers and waterways.

### FEATURES

- Protects environment from hazardous waste
- The solid state device senses between oil and water
- Panel and switch kitted with effluent single phase pumps.
- Only operates pump if water is sensed by probes. Does not operate if oil is present in pit.



CentriPro is a brand of ITT Corporation.

[www.centripro.com](http://www.centripro.com)

*Engineered for life*

### **OIL SMART® SWITCH**

---

- Solid state sensing device that differentiates between oil and water
- Two sense points, Pump On and Pump Off, reduces the risk of pumping oil or other hydrocarbons into the environment
- Includes mounting hardware
- Pump On position is the shorter rod
- Pump Off position is the longer rod
- Pumping Differential: 6"
- Dimensions: 2.5" wide x 6" high (body less rods) x 1.75" deep.
- 20' cord
- Completely encapsulated and water-tight.
- CE, UL 508, UL Marine and CUL Listings
- Exceeds U.S. Coast Guard Standards.
- Complies with State and Federal regulations and reduces the risk of adverse publicity and expensive cleanup costs.

**Part Number** A1SEEWATER  
A1SEEWATERP (with plug)

### **OIL SMART® ALARM**

---

- Alarm leak or liquid detection
- 120V
- Includes Liquid Smart® Sensor
- Sensor differentiates between oil and water
- Alarm indication differentiates liquid
- Dry contacts

**Part Number** A4-SEE1

### **SIMPLEX PANEL**

---

- Simplex, 115 or 230 volt, 1Ø Panel in rugged NEMA 4X fiberglass enclosure with locking hasp and hinged door.
- Use with our model A1SEEWATER Oil Smart sensor to control a sump/effluent pump in areas where oil may be present.
- The sensor differentiates between oil and water. The panel and sensor will not allow the pump to operate unless water is present, eliminating environmental contamination and costly oil cleanups.
- High level alarm features a top mounted high intensity red alarm light with 360° visibility and a 95db corrosion resistant alarm horn.
- Terminal strip with connections
- Entire panel is UL and CUL Listed.

**Part Number S120ENPR**

*\* Switch not included.*

### **DUPLEX PANEL**

---

- 1Ø Panel, 115 / 208 / 230 volt
- Two 20 amp motor start relays
- Operates pumps: up to ¾ HP at 120V  
up to 2 HP at 230V
- Includes Liquid Smart® alarm sensor
- Alarm indication differentiates liquid
- Includes high water 2-pump demand switch
- Includes Oil Smart® pump controller
- Alternation, 2-pump high demand, pump no load lockout.
- Seal fail fault and high temperature
- NEMA 4X enclosure
- Dry contacts

**Part Number D1SEE20**

*\* Switch and controller included.*

### SIMPLEX PANEL — S120ENPR

#### ENCLOSURE DIMENSIONS (IN INCHES)

##### Single Phase

A	B	C	D	E	F	G
6.3	11.5	14.3	10.8	5.5	6.0	9.3

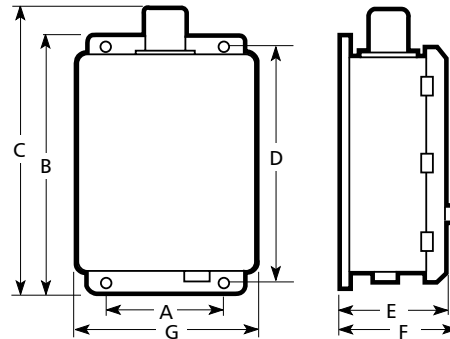

#### WIRING DIAGRAM

FOR 115 VOLT OPERATION  
USE TERMINALS (L1) AND (N)  
JUMP TERMINALS (N) AND (L2)

230 VAC  
SINGLE PHASE  
60 HZ

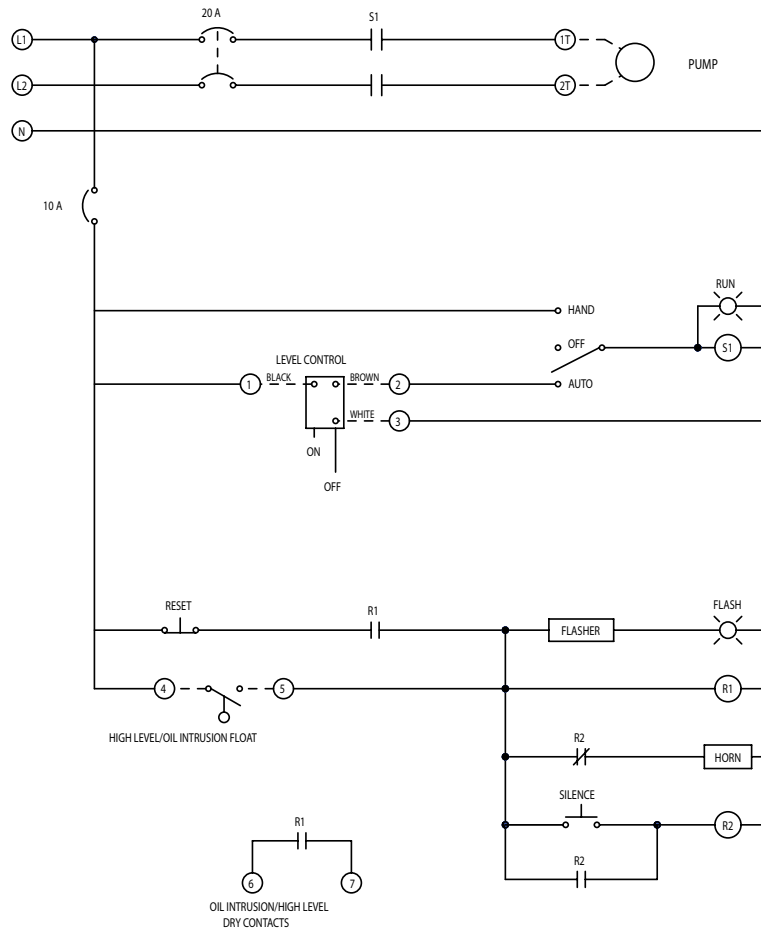

## DUPLEX PANEL — D1SEE20

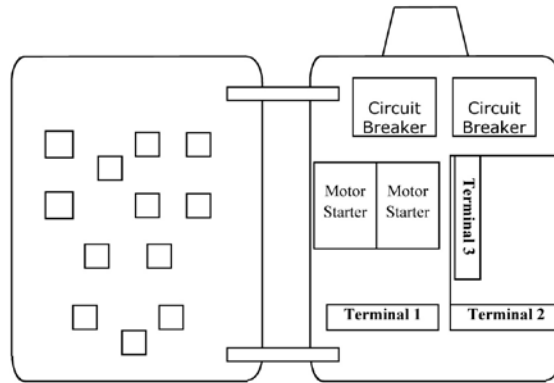

### Terminal 1 (Pumps)

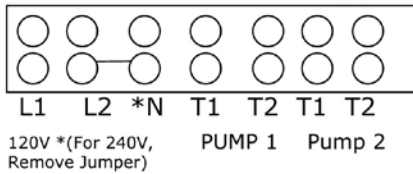

### Terminal 2 (Alarm)

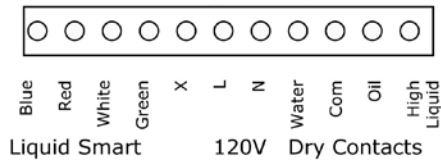

### Terminal 3 (Pump Controls)

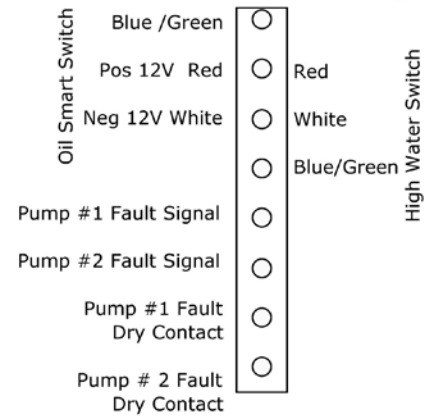

### PUMP INSTALLATION

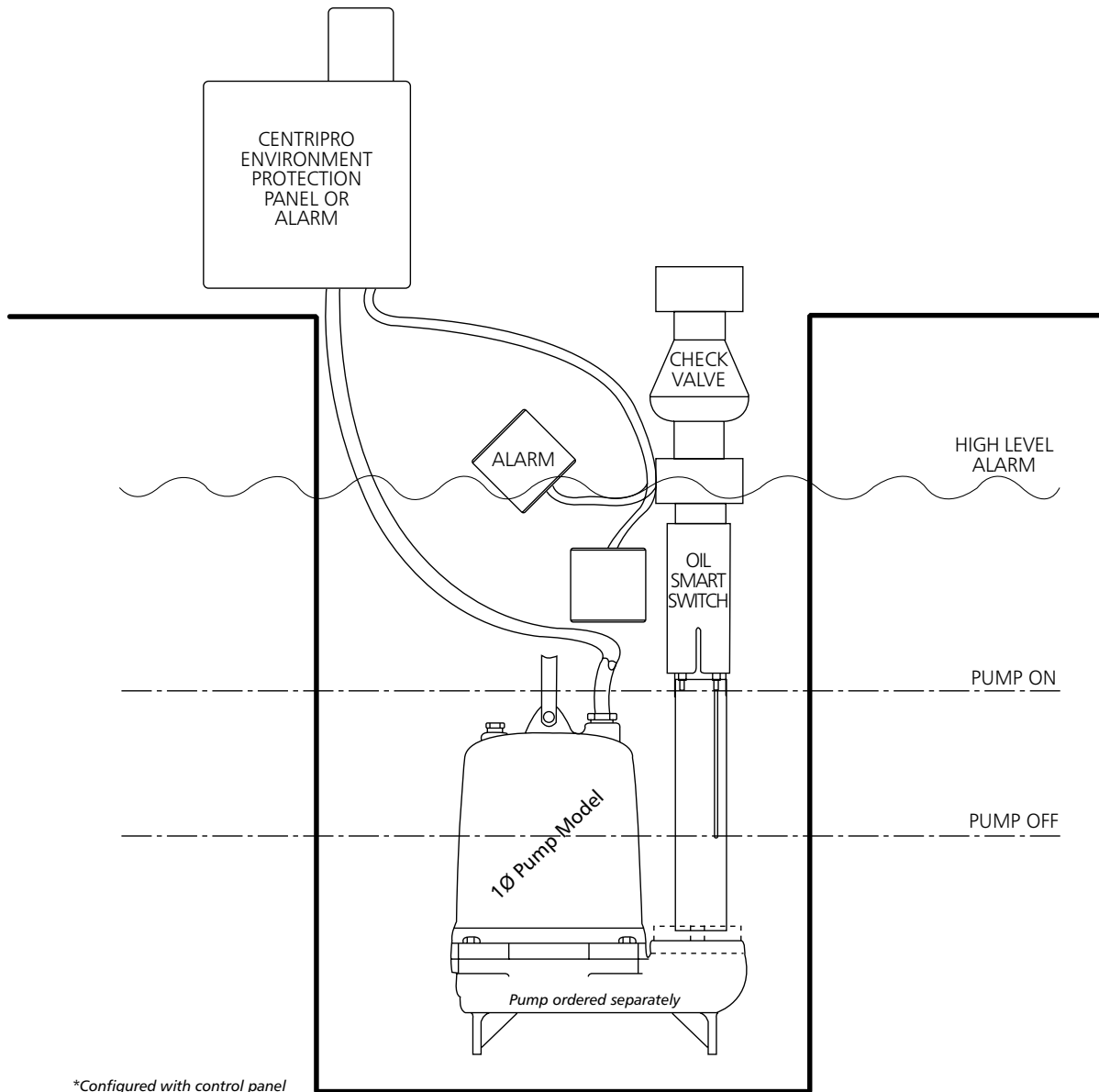

### CONTROL KITS

#### A1SEEWATERKIT

*Includes:*

- S120ENPR – Panel
- A1SEEWATER – Oil Smart Switch
- A2N33 – 20 foot Alarm Float Switch Bare Leads  
(Pump 1Ø up to 20 Amps - purchased separately)

#### A1SEEWATER1

*Includes:*

- A1SEEWATERP – Switch with plug
- A4-SEE1 – Alarm

#### D1SEE20

*Includes:*

- Duplex Panel
  - Alarm
  - Controller
  - Switch

### ELEVATOR PUMP KITS

Brand	Pump	Panel	Oil Smart Switch	Alarm Float	Pump
Goulds	ELKTWE0311L	S120ENPR	A1SEEWATER	A2N33	WE0311L
	ELKTWE0511H				WE0511H
	ELKTWE0512H				WE0512H
B&G	ELKT2EC0311L				2EC0311L
	ELKT2EC0511H				2EC0511H
	ELKT2EC0512H				2EC0512H

### FEATURES FOR PUMP

- Effluent, 1/3 or 1/2 HP, single phase pump
- Hard faced seal
- Cast iron construction

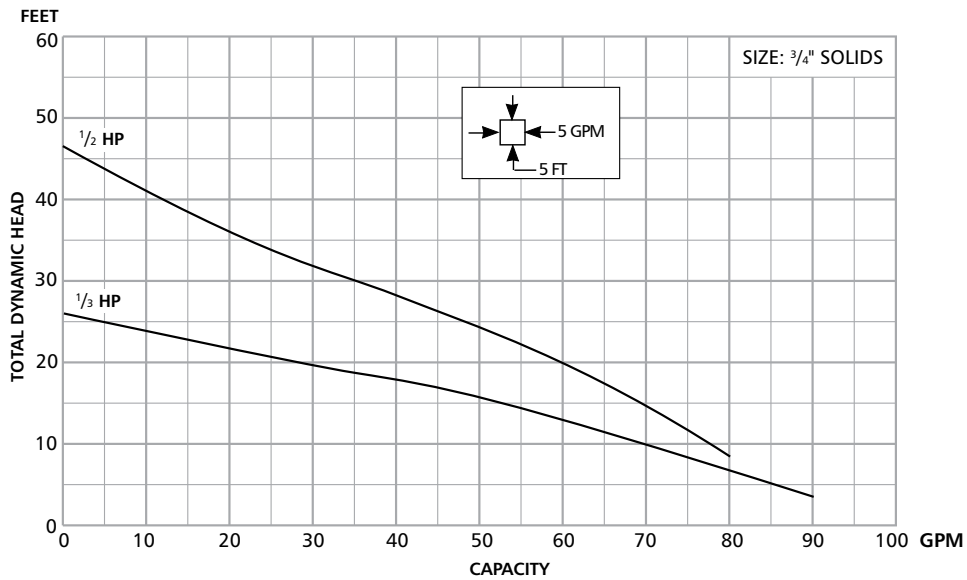

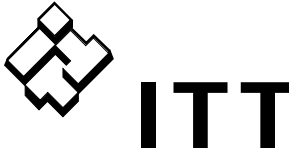

## ELEVATOR PUMP KIT CONTENTS

Solution	Kit	Includes				
		Panel	Oil Smart Switch	Oil Smart Alarm	Alarm Float	Pump
Good	A1SEEWATER/P	Not Included	A1SEEWATERP	A4-SEE1	Sensor Included	Not Included
Better	A1SEEWATER KIT	S120ENPR	A1SEEWATER	Not Included	A2N33	Not Included
Best	ELKT2EC0311L	S120ENPR	A1SEEWATER	Not Included	A2N33	2EC0311L, ½ HP 115 V
Best	ELKT2EC0511H	S120ENPR	A1SEEWATER	Not Included	A2N33	2EC0511H, ½ HP, 115 V
Best	ELKT2EC0512H	S120ENPR	A1SEEWATER	Not Included	A2N33	2EC0512H, ½ HP, 230 V
Best	ELKTWE0311L	S120ENPR	A1SEEWATER	Not Included	A2N33	WE0311L, ½ HP 115 V
Best	ELKTWE0511H	S120ENPR	A1SEEWATER	Not Included	A2N33	WE0511H, ½ HP 115V
Best	ELKTWE0512H	S120ENPR	A1SEEWATER	Not Included	A2N33	WE0512H, ½ HP 230V
Duplex	D1SEE20	D1SEE20	Duplex Device Included	Not Included	Duplex Device Included	Not Included



ITT  
 2881 East Bayard Street, Seneca Falls, NY 13148  
 Phone: (315) 568-7123 • Fax: (315) 568-7973  
[www.centripro.com](http://www.centripro.com)

CentriPro and See Water are registered trademarks of ITT Corporation. ITT, the Engineered Blocks Symbol and Engineered for Life are registered trademarks of ITT Manufacturing Enterprises, Inc.  
 Oil Smart is a registered trademark of See Water Inc.