

A Full Range of Product Features, Una Gama Total de Características del Producto

Superior Materials of Construction:

AISI Type 304SS pump parts for reduced corrosion and improved strength and ductility.

Frame Mounted Design:

Flexibility of installation and driver arrangements.

Back Pull-Out Design: Simplifies maintenance when used with spacer type coupling.

Cast Iron Power Frame: Rigidly supported, grease lubricated ball bearing assembly.

Mechanical Seal: Standard John Crane Type 21 mechanical seal.

Drive Motors: Standard NEMA design T-frame or JM motors in single or three phase.

Suction and Discharge

Flanges: Mate with ANSI class 150 flanges.

Close-Coupled Design: Compact design saves space and simplifies maintenance.

Materiales Superiores de Construcción:

Partes de la bomba de acero inoxidable AISI Tipo 304 para corrosión reducida y fuerza y ductilidad mejoradas.

Diseño de Armazón Montado:

Flexibilidad de instalación y colocación del motor.

Diseño de Extracción Trasera:

Simplifica el mantenimiento cuando se usa con el acople tipo espaciador.

Armazón del Motor de Hierro Fundido:

Rígidamente soportado, con ensamblaje de balineras de bolas lubricadas con grasa.

Sello Mecánico: Sello mecánico estándar John Crane Tipo 21.

Motores de Accionamiento:

Motores de armazón-T NEMA estándar unifásicos o trifásicos.

Bridas de Succión y Descarga:

Acoplan con bridas ANSI clase 150.

Diseño de Acople Cerrado:

El diseño compacto ahorra espacio y simplifica el mantenimiento.

Performance Coverage, 3500 and 1750 RPM Alcance de Funcionamiento, 3500 y 1750 RPM

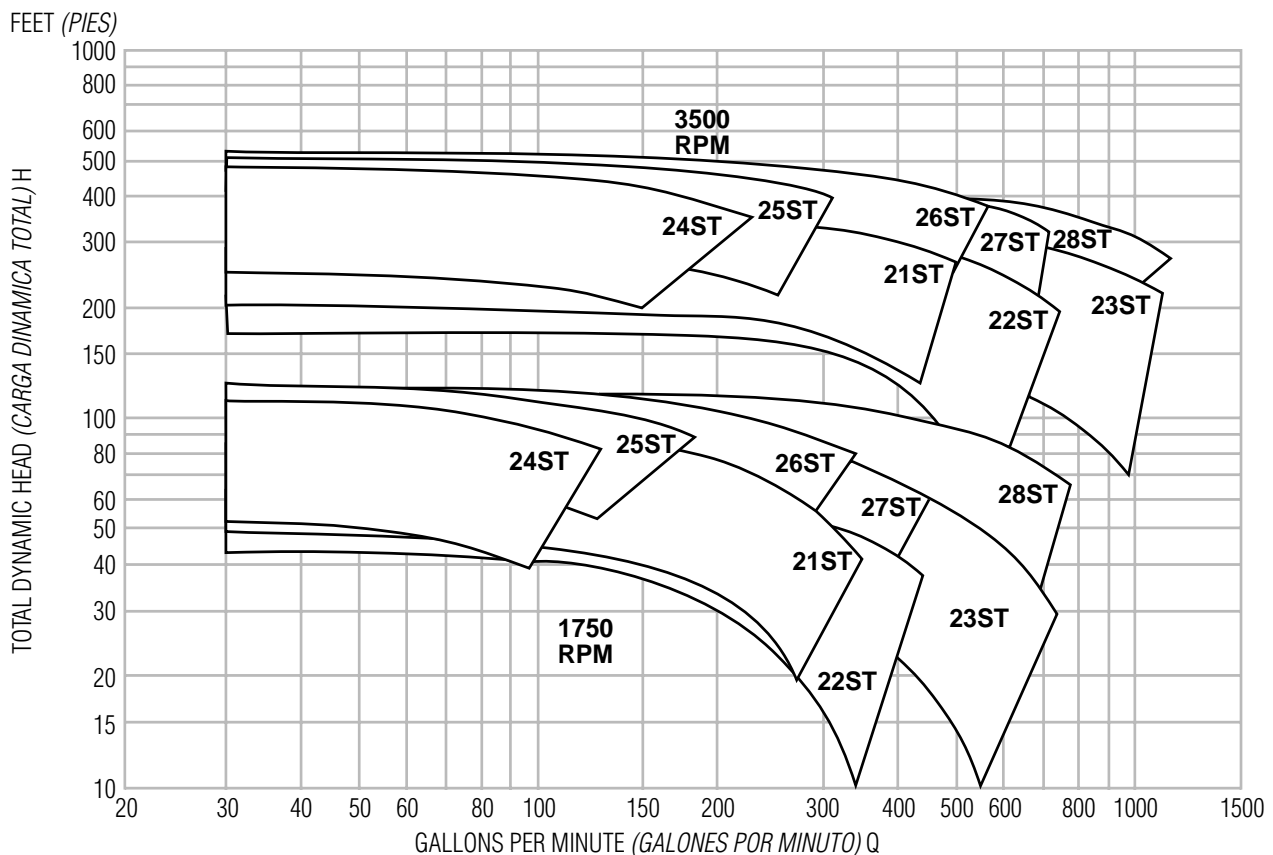

SST M-Group Numbering System

Sistema de Numeración del Grupo-M SST

Example Product Code, Ejemplo Código del Producto

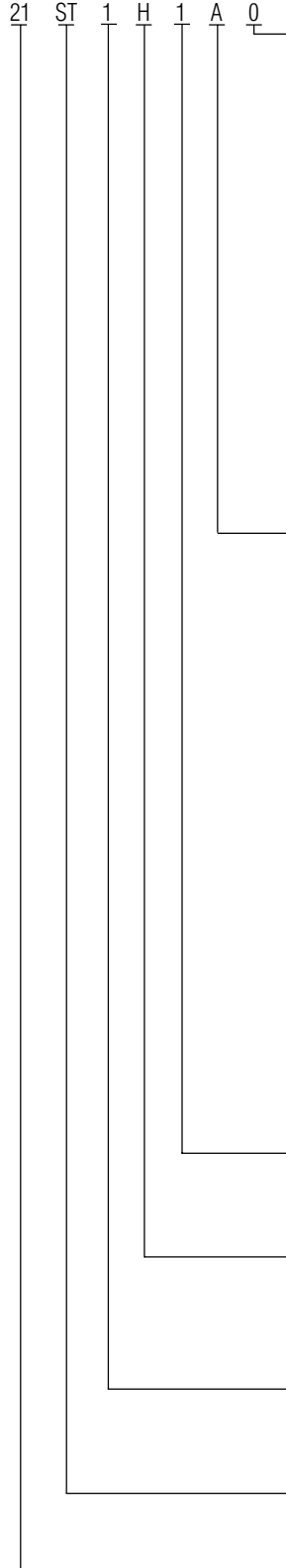

Mechanical Seals and O-Ring

0 = Pre-engineered standard
For optional mechanical seal modify catalog order no. with seal code listed below.

Sello Mecánico y Anillo '0'

0 = Estándar aprobado
Para sello mecánico opcional modificar el número de orden del catálogo con el código del sello anotado abajo.

John Crane Type 21 Mechanical Seal, Sello Mecánico John Crane Tipo 21							
Seal Code, Código del Sello	Rotary, Rotativo	Stationary, Estacionario	Elastomers, Elastómeros	Metal Parts, Partes Metálicas	Part No., Pieza Número		Casing O-Ring, Carcasa Anillo '0'
					180-210 Frames, Armazones	250-360 Frames, Armazones	
0	Carbon	Ceramic	BUNA	316 SS, 316 Acero inoxidable	10K13	10K16	BUNA
2		Ni-Resist	EPR		10K19	10K20	
3		Ceramic	Viton		10K25	10K26	Viton
4		Tung-Carb			10K27	10K45	

Impeller Option Code

For optional impeller diameters modify catalog order no. with impeller code listed below.
Select optional impeller diameter from pump performance curve.

Código del Impulsor Opcional

Para diámetros del impulsor opcional modificar el número de orden del catálogo con el código del impulsor anotado abajo.
Seleccionar el diámetro del impulsor opcional de la curva de funcionamiento de la bomba.

Impeller Code, Código del impulsor	Pump Size, Tamaño de la Bomba							
	21ST	22ST	23ST	24ST	25ST	26ST	27ST	28ST
	2 x 2½ - 8	2½ x 3 - 8	3 x 4 - 8	1¼ x 2 - 10	1½ x 2½ - 10	2 x 2½ - 10	2½ x 3 - 10	3 x 4 - 10
	Diameter	Diameter	Diameter	Diameter	Diameter	Diameter	Diameter	Diameter
A	8⅝	9⅛	9⅛	10⅛	10⅛	10⅛	10⅝	10⅝
B	8⅞	8¾	8⅞	9⅜	9⅜	9⅜	9⅝	10¼
C	8¾	8½	8⅞	9¼	9⅝	9⅞	9⅞	9⅞
D	7⅞	8¼	8⅞	8⅞	9⅞	9⅞	9¼	9⅞
E	7½	7⅞	7⅞	8⅞	8⅞	8⅞	8¾	9⅞
F	7⅞	7½	7½	8¼	8⅞	8⅞	N/A	8⅞
G	6⅞	7⅞	7⅞	7⅞	8⅞	8⅞	N/A	N/A
H	6½	6⅞	6⅞	7¾	7¾	8⅞	N/A	N/A
J	N/A	6½	6½	N/A	N/A	N/A	N/A	N/A

Driver, Conductor

1 = 1 PH, ODP 3 = 575 V, ODP 5 = 3 PH, TEFC 7 = 3 PH, XP 9 = 3 PH, TEFC Premium Eff.
2 = 3 PH, ODP 4 = 1 PH, TEFC 6 = 575 V, TEFC 8 = 575 V, XP

HP Rating, HP Potencia

E = 1 HP H = 3 HP L = 10 HP P = 25 HP S = 50 HP V = 100 HP
F = 1½ HP J = 5 HP M = 15 HP Q = 30 HP T = 60 HP
G = 2 HP K = 7½ HP N = 20 HP R = 40 HP U = 75 HP

Driver: Hertz/Pole/RPM, Conductor: Hercios/Polo/RPM

1 = 60 Hz, 2 pole, 3500 RPM 3 = 60 Hz, 6 pole, 1150 RPM 5 = 50 Hz, 4 pole, 1450 RPM
2 = 60 Hz, 4 pole, 1750 RPM 4 = 50 Hz, 2 pole, 2900 RPM

Material

ST = Stainless steel, Acero inoxidable

Pump Size, Tamaño de la Bomba

21 = 2 x 2½ - 8 24 = 1¼ x 2 - 10 27 = 2½ x 3 - 10
22 = 2½ x 3 - 8 25 = 1½ x 2½ - 10 28 = 3 x 4 - 10
23 = 3 x 4 - 8 26 = 2 x 2½ - 10

For frame mounted pumps substitute the letters "FRM".

Para bombas con armazón montado sustituya las letras "FRM".

NOTE: Not all combinations of motor, impeller and seal options are available for every pump model. Please check with G&L on non-cataloged numbers.

NOTA: No todas las combinaciones de las opciones de motor, impulsor y sello están disponibles para cada modelo de bombas. Por favor verifique con G&L en los números no catalogados.

Performance Curves – 60 Hz, 3500 RPM
Curvas de Funcionamiento – 60 Hz, 3500 RPM

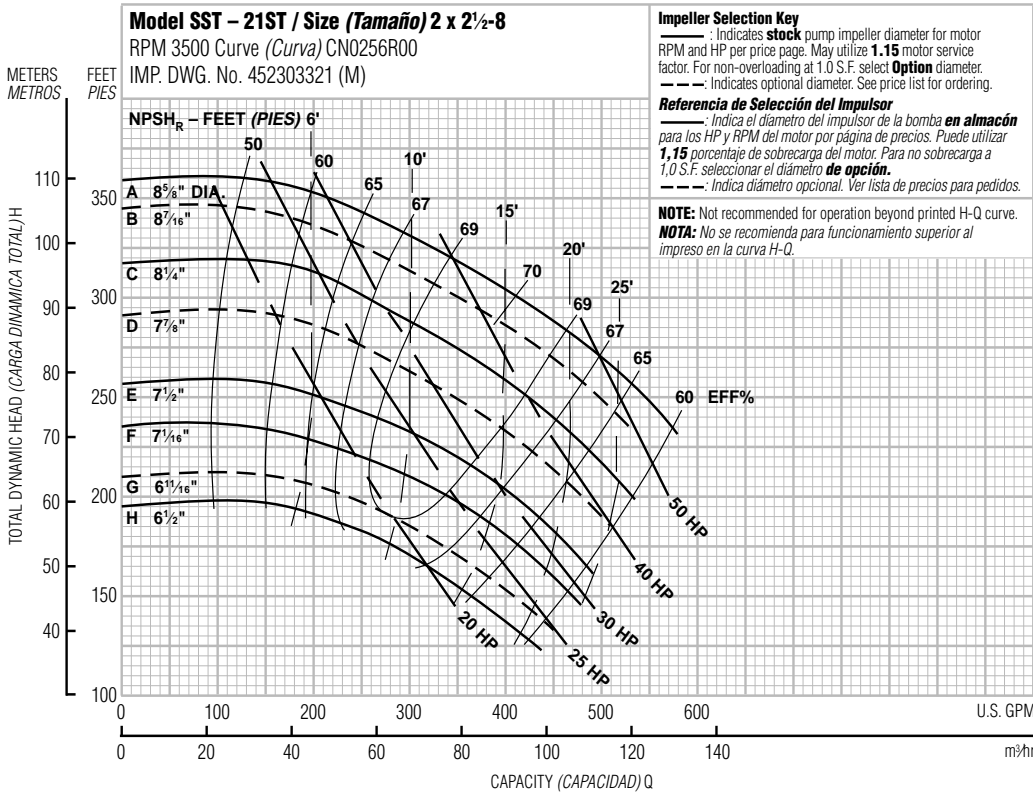

Optional Impeller, Impulsor Opcional

Ordering Code, Código de Pedido	Standard HP Rating, Estándar HP Potencia	Dia.
A	50	8 5/8"
B	50	8 7/16"
C	40	8 1/4"
D	40	7 7/8"
E	30	7 1/2"
F	25	7 1/16"
G	25	6 1 1/16"
H	20	6 1/2"

NOTE: Pump will pass a sphere to 3/16" diameter.
NOTA: La bomba pasará una esfera a 3/16" diámetro.

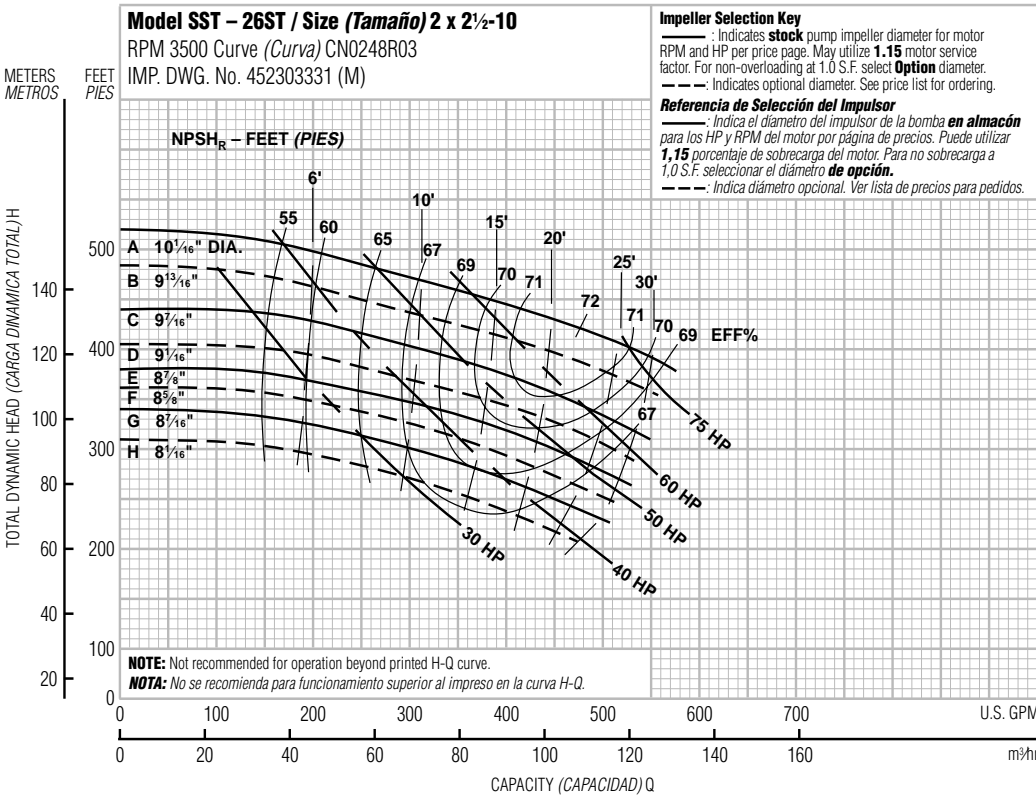

Optional Impeller, Impulsor Opcional

Ordering Code, Código de Pedido	Standard HP Rating, Estándar HP Potencia	Dia.
A	75	10 1/16"
B	75	9 13/16"
C	60	9 7/16"
D	60	9 1/16"
E	50	8 7/8"
F	50	8 5/8"
G	40	8 7/16"
H	40	8 1/16"

NOTE: Pump will pass a sphere to 1/2" diameter.
NOTA: La bomba pasará una esfera a 1/2" diámetro.

Performance Curves – 60 Hz, 3500 RPM
Curvas de Funcionamiento – 60 Hz, 3500 RPM

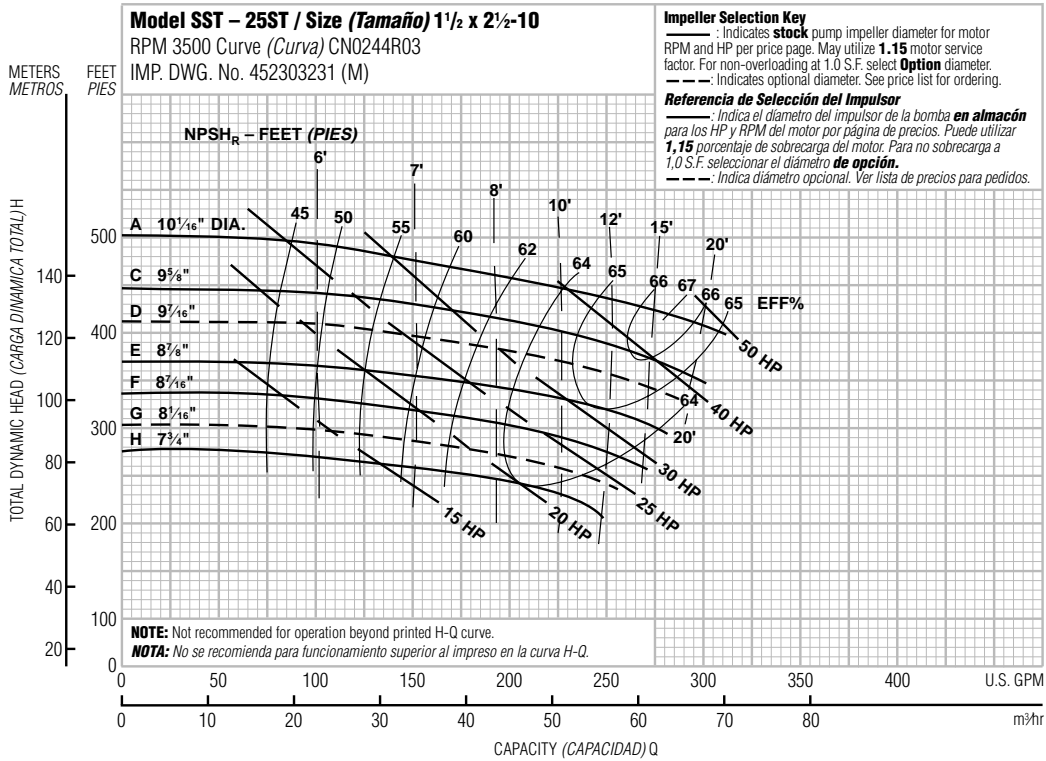

Optional Impeller, Impulsor Opcional		
Ordering Code, Código de Pedido	Standard HP Rating, Estándar HP Potencia	Dia.
A	40	10 ¹ / ₁₆ "
B	30	9 ¹³ / ₁₆ "
C	25	9 ¹ / ₄ "
D	25	8 ⁷ / ₈ "
E	20	8 ⁵ / ₈ "
F	20	8 ¹ / ₄ "
G	15	7 ⁷ / ₈ "
H	15	7 ³ / ₄ "

NOTE: Pump will pass a sphere to 5/32" diameter.

NOTA: La bomba pasará una esfera a 5/32" diámetro.

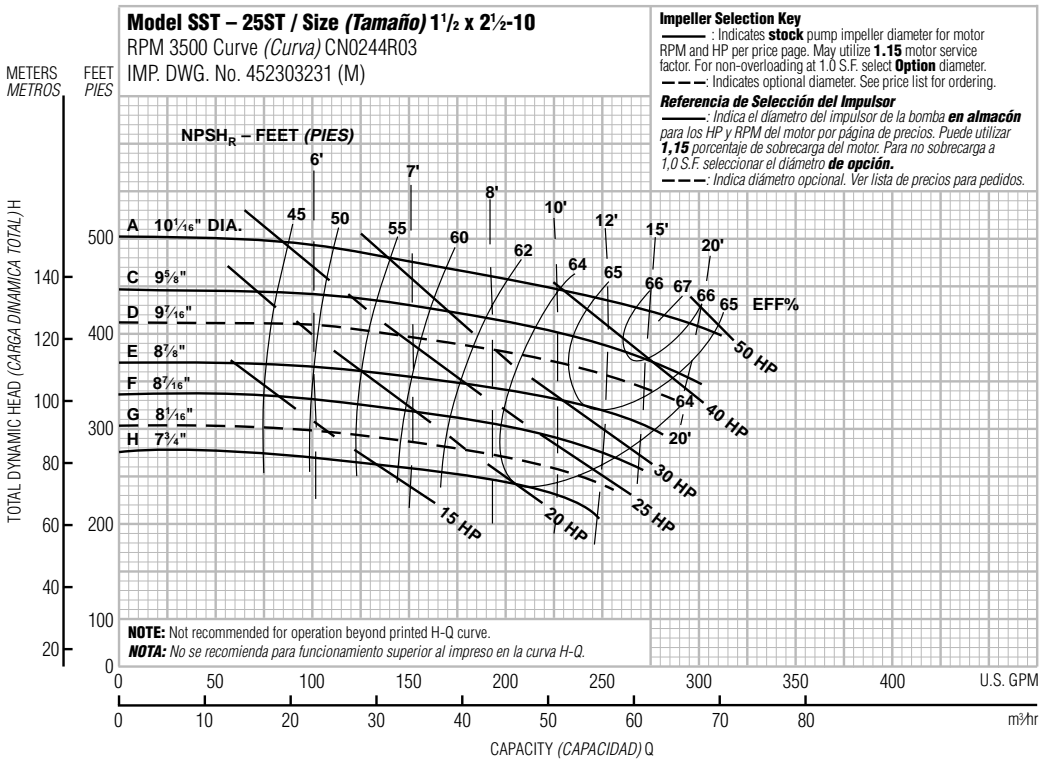

Optional Impeller, Impulsor Opcional		
Ordering Code, Código de Pedido	Standard HP Rating, Estándar HP Potencia	Dia.
A	50	10 ¹ / ₁₆ "
C	40	9 ⁵ / ₈ "
D	40	9 ⁷ / ₁₆ "
E	30	8 ⁷ / ₈ "
F	25	8 ⁷ / ₁₆ "
G	25	8 ¹ / ₁₆ "
H	20	7 ³ / ₄ "

NOTE: Pump will pass a sphere to 5/16" diameter.

NOTA: La bomba pasará una esfera a 5/16" diámetro.

Performance Curves – 60 Hz, 3500 RPM
Curvas de Funcionamiento – 60 Hz, 3500 RPM

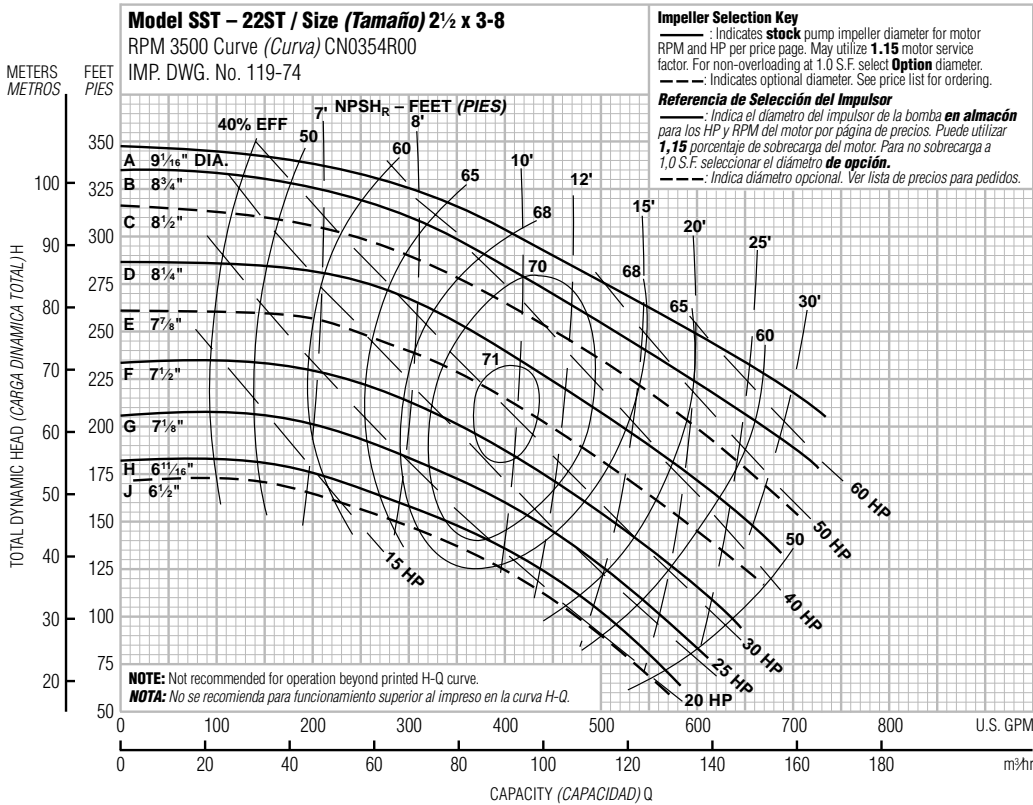

Optional Impeller, Impulsor Opcional		
Ordering Code, Código de Pedido	Standard HP Rating, Estándar HP Potencia	Dia.
A	60	9 1/16"
B	50	8 3/4"
C	50	8 1/2"
D	40	8 1/4"
E	40	7 7/8"
F	30	7 1/2"
G	25	7 1/8"
H	20	6 1 1/16"
J	20	6 1/2"

NOTE: Pump will pass a sphere to 19/32" diameter.

NOTA: La bomba pasará una esfera a 19/32" diámetro.

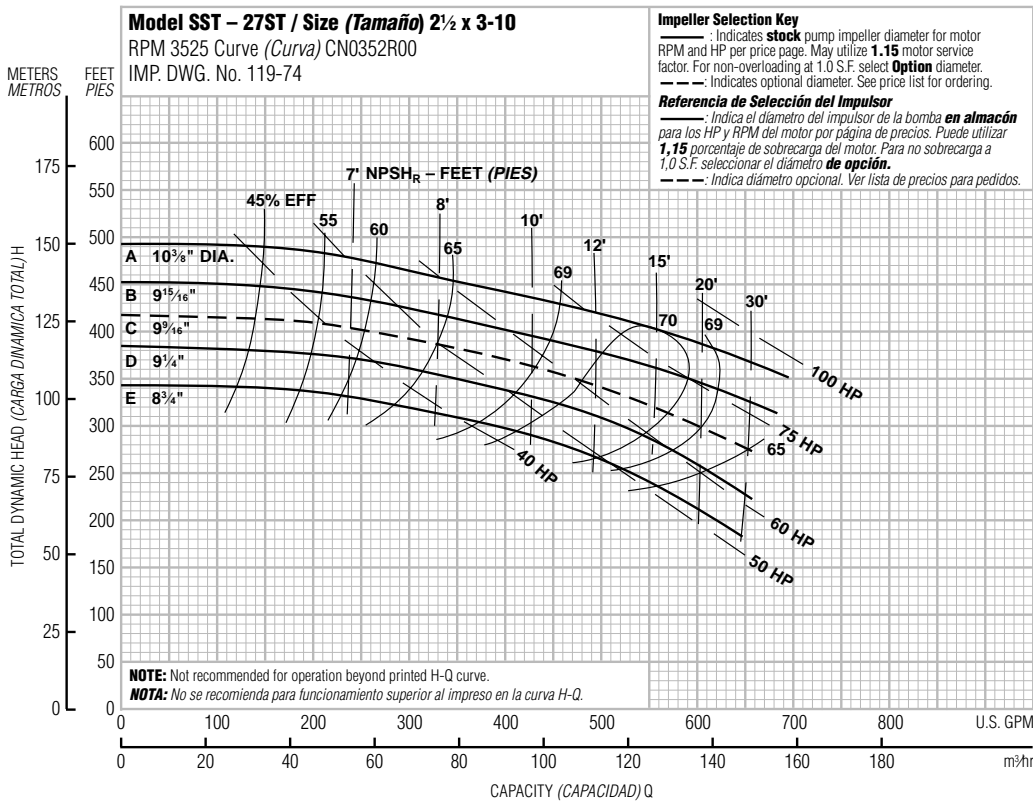

Optional Impeller, Impulsor Opcional		
Ordering Code, Código de Pedido	Standard HP Rating, Estándar HP Potencia	Dia.
A	100	10 3/8"
B	75	9 15/16"
C	75	9 7/16"
D	60	9 1/4"
E	50	8 3/4"

NOTE: Pump will pass a sphere to 19/32" diameter.

NOTA: La bomba pasará una esfera a 19/32" diámetro.

Performance Curves – 60 Hz, 3500 RPM
Curvas de Funcionamiento – 60 Hz, 3500 RPM

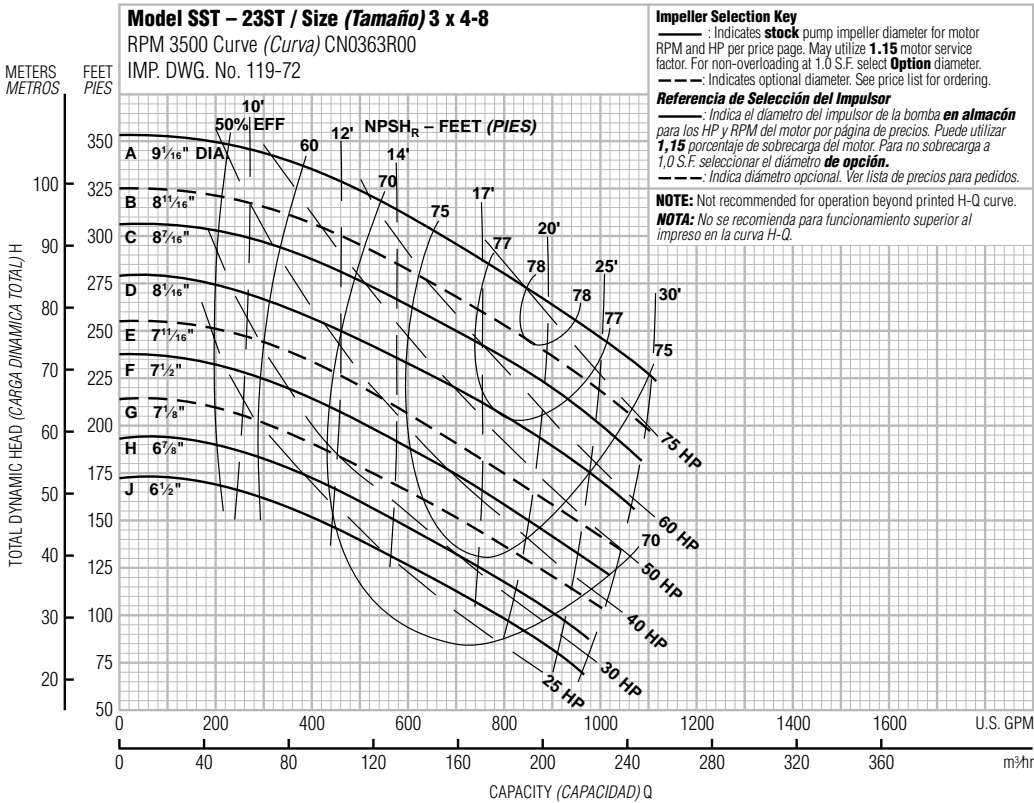

Optional Impeller, Impulsor Opcional		
Ordering Code, Código de Pedido	Standard HP Rating, Estándar HP Potencia	Dia.
A	75	9 ¹ / ₁₆ "
B	75	8 ¹ / ₁₆ "
C	60	8 ⁷ / ₁₆ "
D	50	8 ¹ / ₁₆ "
E	50	7 ¹ / ₁₆ "
F	40	7 ¹ / ₂ "
G	40	7 ¹ / ₈ "
H	30	6 ⁷ / ₈ "
J	25	6 ¹ / ₂ "

NOTE: Pump will pass a sphere to 3/4" diameter.

NOTA: La bomba pasará una esfera a 3/4" diámetro.

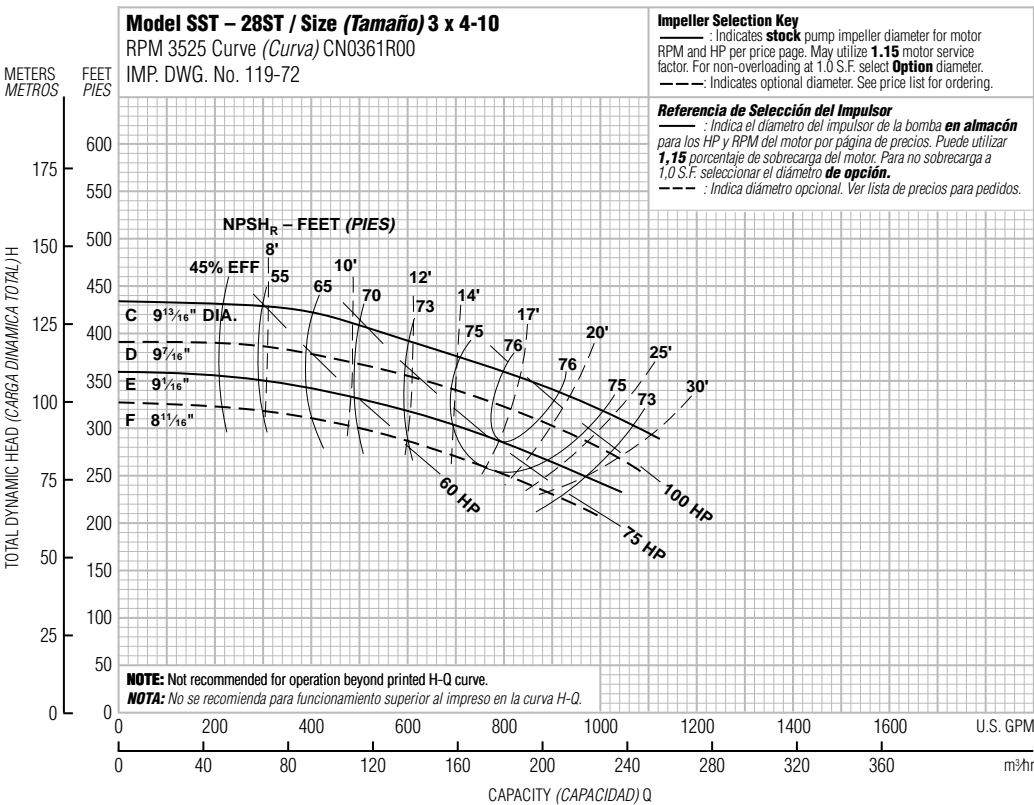

Optional Impeller, Impulsor Opcional		
Ordering Code, Código de Pedido	Standard HP Rating, Estándar HP Potencia	Dia.
C	100	9 ¹³ / ₁₆ "
D	100	9 ⁷ / ₁₆ "
E	75	9 ¹ / ₁₆ "
F	75	8 ¹ / ₁₆ "

NOTE: Pump will pass a sphere to 3/4" diameter.

NOTA: La bomba pasará una esfera a 3/4" diámetro.

Performance Curves – 60 Hz, 1750 RPM
Curvas de Funcionamiento – 60 Hz, 1750 RPM

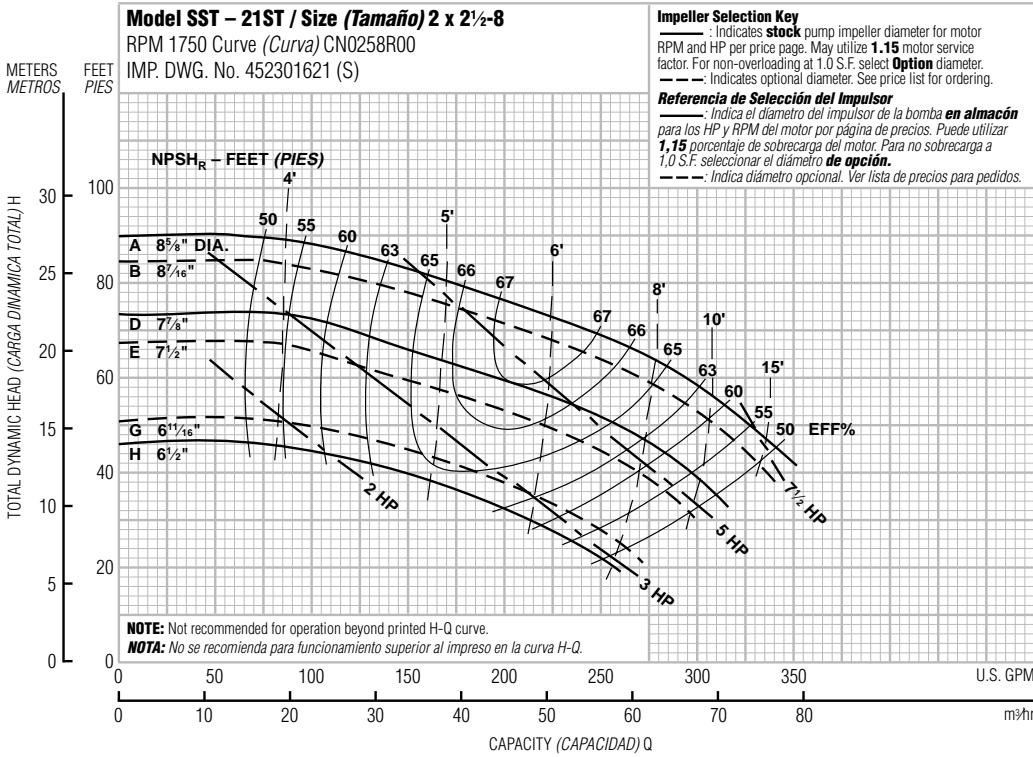

Optional Impeller, Impulsor Opcional		
Ordering Code, Código de Pedido	Standard HP Rating, Estándar HP Potencia	Dia.
A	7½	8 ⁵ / ₈ "
B	7½	8 ⁷ / ₁₆
D	5	7 ⁷ / ₈
E	5	7½
G	3	6 ¹ / ₁₆
H	3	6½

NOTE: Pump will pass a sphere to 9/16" diameter.

NOTA: La bomba pasará una esfera a 9/16" diámetro.

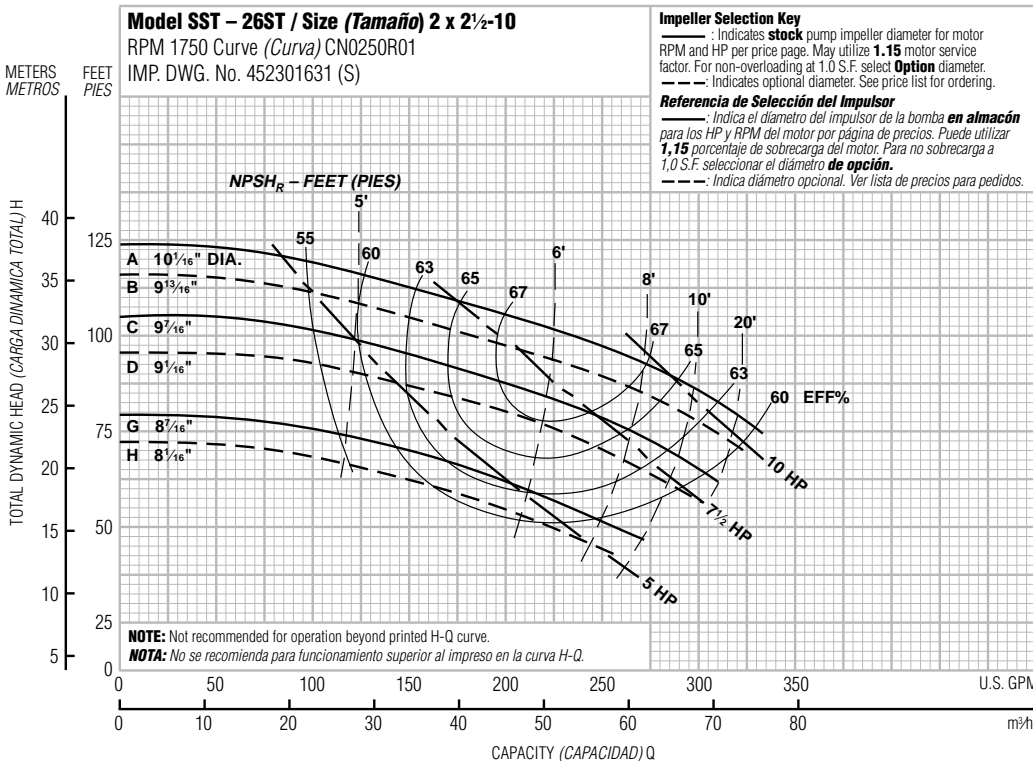

Optional Impeller, Impulsor Opcional		
Ordering Code, Código de Pedido	Standard HP Rating, Estándar HP Potencia	Dia.
A	10	10 ¹ / ₁₆ "
B	10	9 ¹³ / ₁₆
C	7½	9 ⁷ / ₁₆
D	7½	9 ¹ / ₁₆
G	5	8 ⁷ / ₁₆
H	5	8 ¹ / ₁₆

NOTE: Pump will pass a sphere to ½" diameter.

NOTA: La bomba pasará una esfera a ½" diámetro.

Performance Curves – 60 Hz, 1750 RPM
Curvas de Funcionamiento – 60 Hz, 1750 RPM

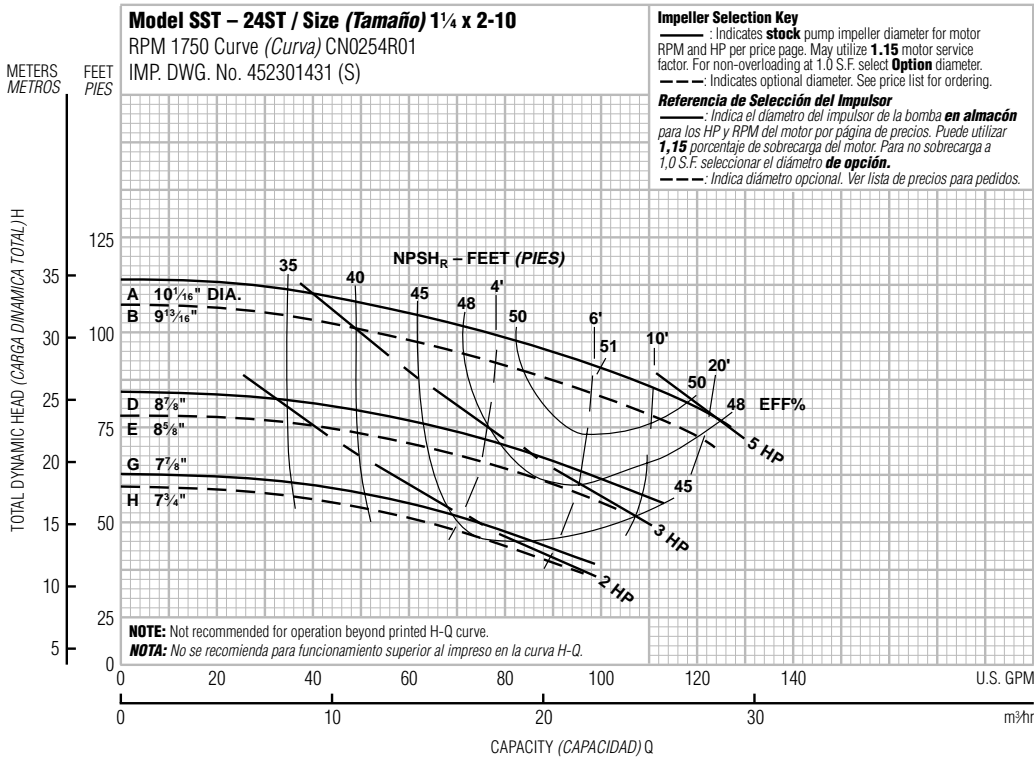

Optional Impeller, Impulsor Opcional		
Ordering Code, Código de Pedido	Standard HP Rating, Estándar HP Potencia	Dia.
A	5	10 1/16"
B	5	9 3/16"
D	3	8 7/8"
E	3	8 5/8"
G	2	7 7/8"
H	2	7 3/4"

NOTE: Pump will pass a sphere to 5/32" diameter.
NOTA: La bomba pasará una esfera a 5/32" diámetro.

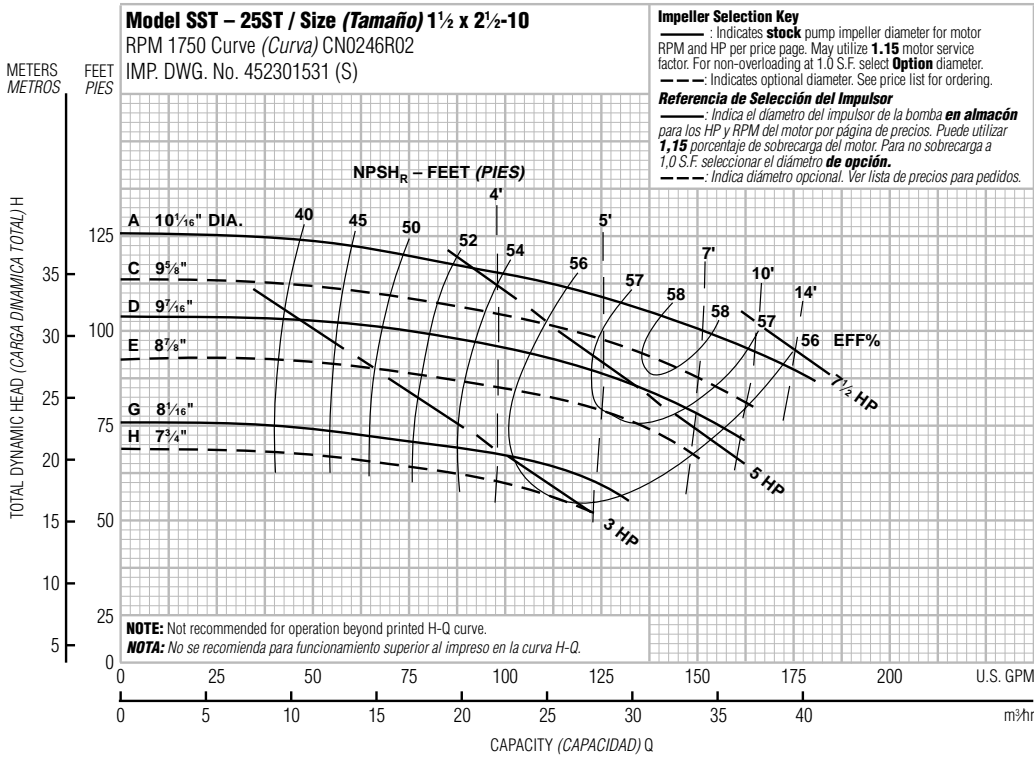

Optional Impeller, Impulsor Opcional		
Ordering Code, Código de Pedido	Standard HP Rating, Estándar HP Potencia	Dia.
A	7 1/2	10 1/16"
C	7 1/2	9 5/8"
D	5	9 7/16"
E	5	8 7/8"
G	3	8 1/16"
H	3	7 3/4"

NOTE: Pump will pass a sphere to 5/16" diameter.
NOTA: La bomba pasará una esfera a 5/16" diámetro.

Performance Curves – 60 Hz, 1750 RPM
Curvas de Funcionamiento – 60 Hz, 1750 RPM

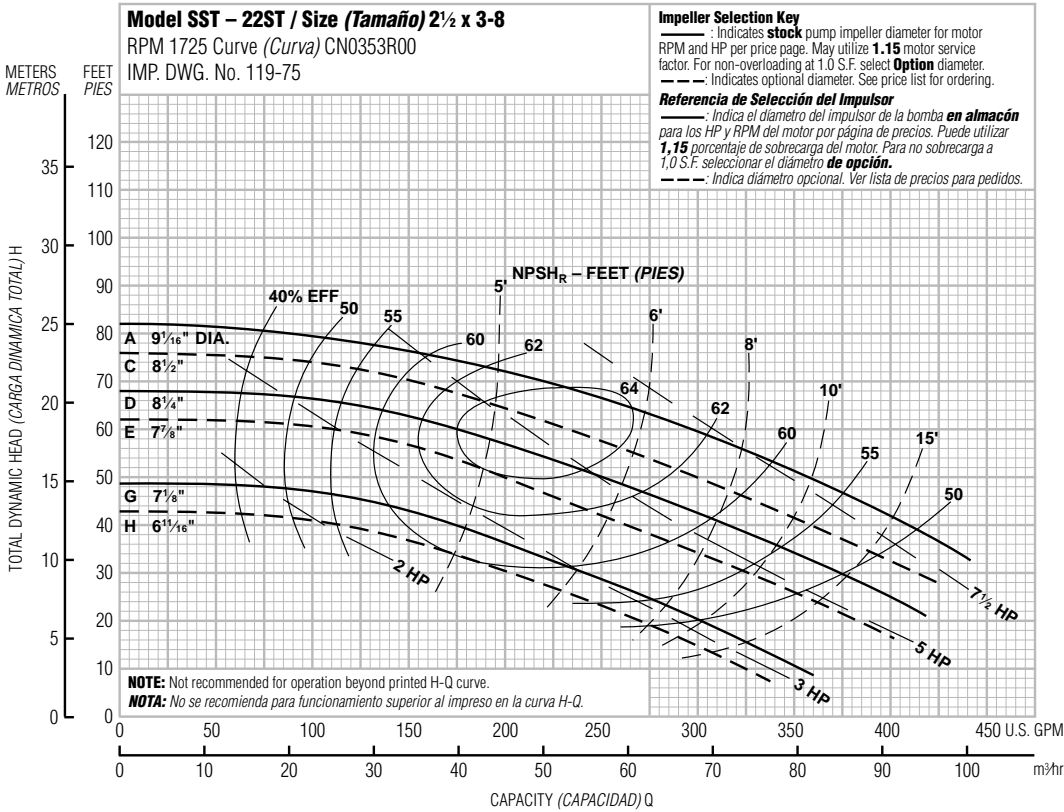

Optional Impeller, Impulsor Opcional		
Ordering Code, Código de Pedido	Standard HP Rating, Estándar HP Potencia	Dia.
A	7½	9½"
C	7½	8½"
D	5	8¼"
E	5	7⅞"
G	3	7⅞"
H	3	6⅞"

NOTE: Pump will pass a sphere to 1½" diameter.

NOTA: La bomba pasará una esfera a 1½" diámetro.

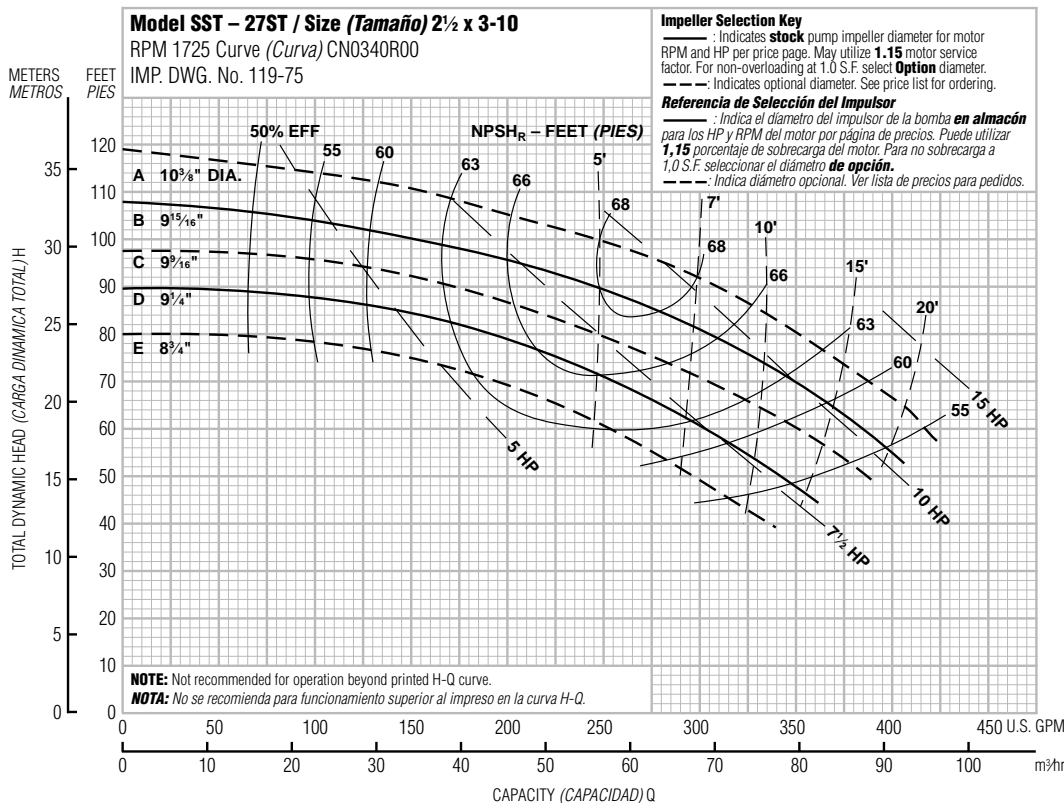

Optional Impeller, Impulsor Opcional		
Ordering Code, Código de Pedido	Standard HP Rating, Estándar HP Potencia	Dia.
A	15	10¾"
B	10	9½"
C	10	9⅞"
D	7½	9¼"
E	7½	8¾"

NOTE: Pump will pass a sphere to 1½" diameter.

NOTA: La bomba pasará una esfera a 1½" diámetro.

Performance Curves – 60 Hz, 1750 RPM
Curvas de Funcionamiento – 60 Hz, 1750 RPM

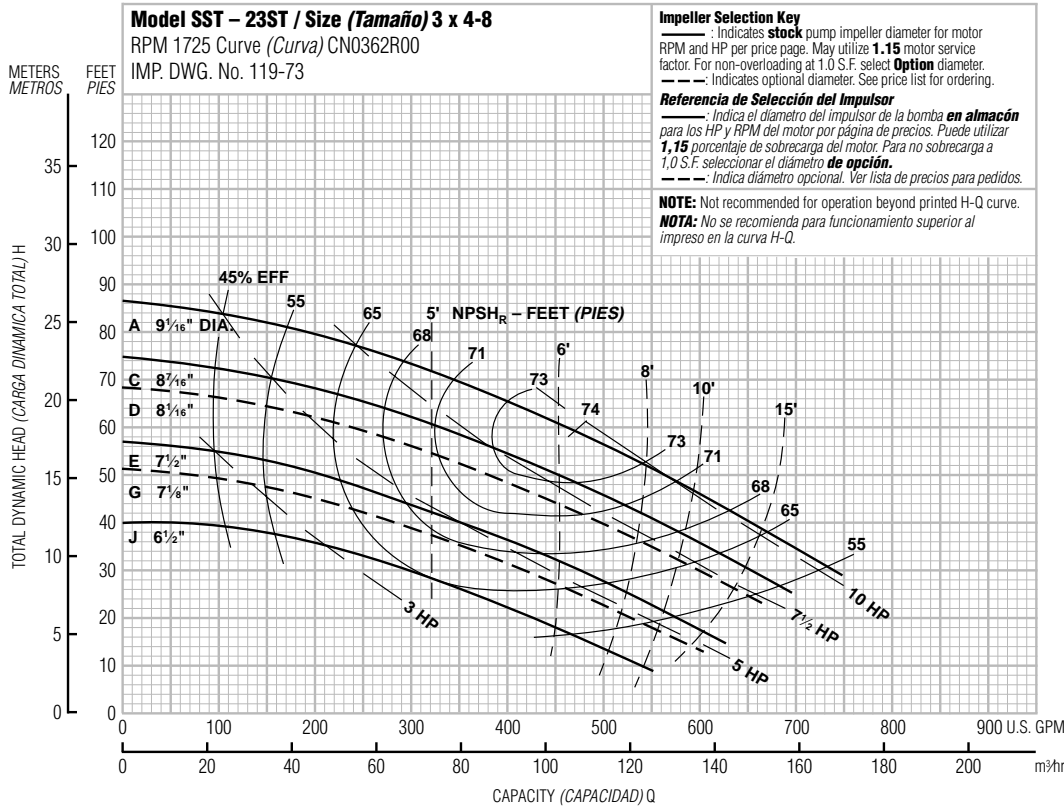

Optional Impeller, Impulsor Opcional		
Ordering Code, Código de Pedido	Standard HP Rating, Estándar HP Potencia	Dia.
A	10	9 1/16"
C	7 1/2	8 7/16
D	7 1/2	8 1/16
F	5	7 1/2
G	5	7 1/8
J	3	6 1/2

NOTE: Pump will pass a sphere to 3/4" diameter.

NOTA: La bomba pasará una esfera a 3/4" diámetro.

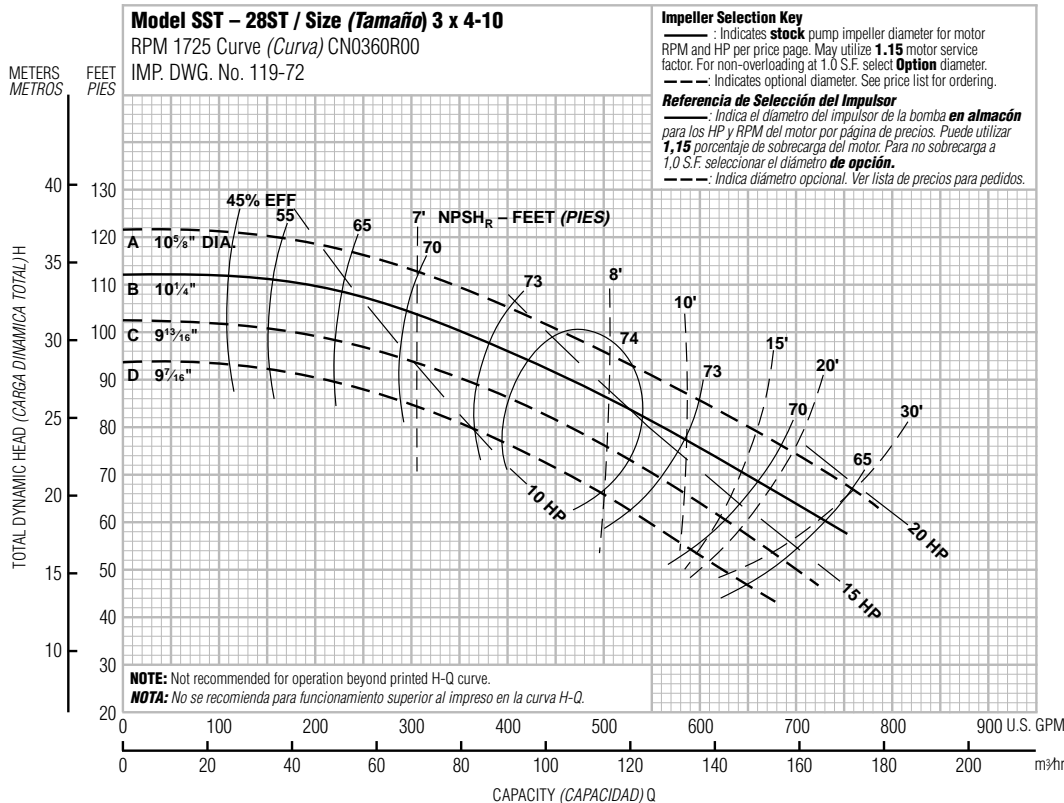

Optional Impeller, Impulsor Opcional		
Ordering Code, Código de Pedido	Standard HP Rating, Estándar HP Potencia	Dia.
A	20	10 5/8"
B	15	10 1/4
C	15	9 13/16
D	15	9 7/16

NOTE: Pump will pass a sphere to 3/4" diameter.

NOTA: La bomba pasará una esfera a 3/4" diámetro.

Performance Curves – 50 Hz, 2900 RPM
Curvas de Funcionamiento – 50 Hz, 2900 RPM

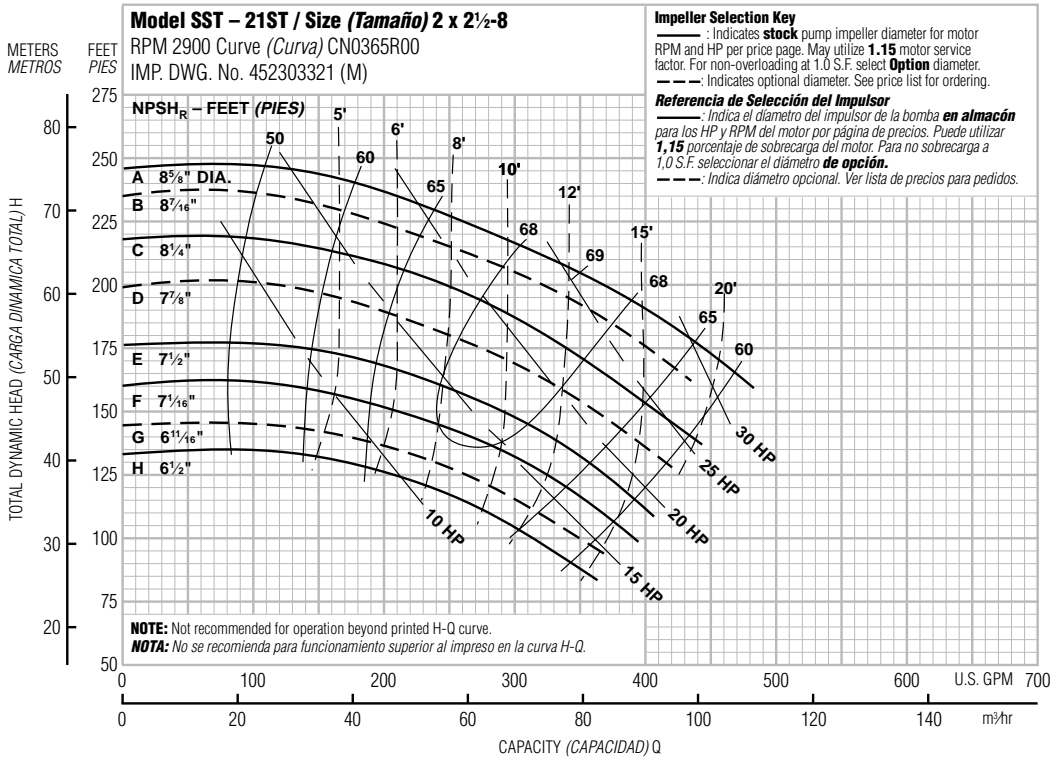

Optional Impeller, Impulsor Opcional		
Ordering Code, Código de Pedido	Standard HP Rating, Estándar HP Potencia	Dia.
A	30	8 ⁵ / ₁₆ "
B	30	8 ⁷ / ₁₆ "
C	25	8 ¹ / ₄ "
D	25	7 ⁷ / ₈ "
E	20	7 ¹ / ₂ "
F	15	7 ¹ / ₁₆ "
G	15	6 ¹¹ / ₁₆ "
H	15	6 ¹ / ₂ "

NOTE: Pump will pass a sphere to 3/16" diameter.

NOTA: La bomba pasará una esfera a 3/16" diámetro.

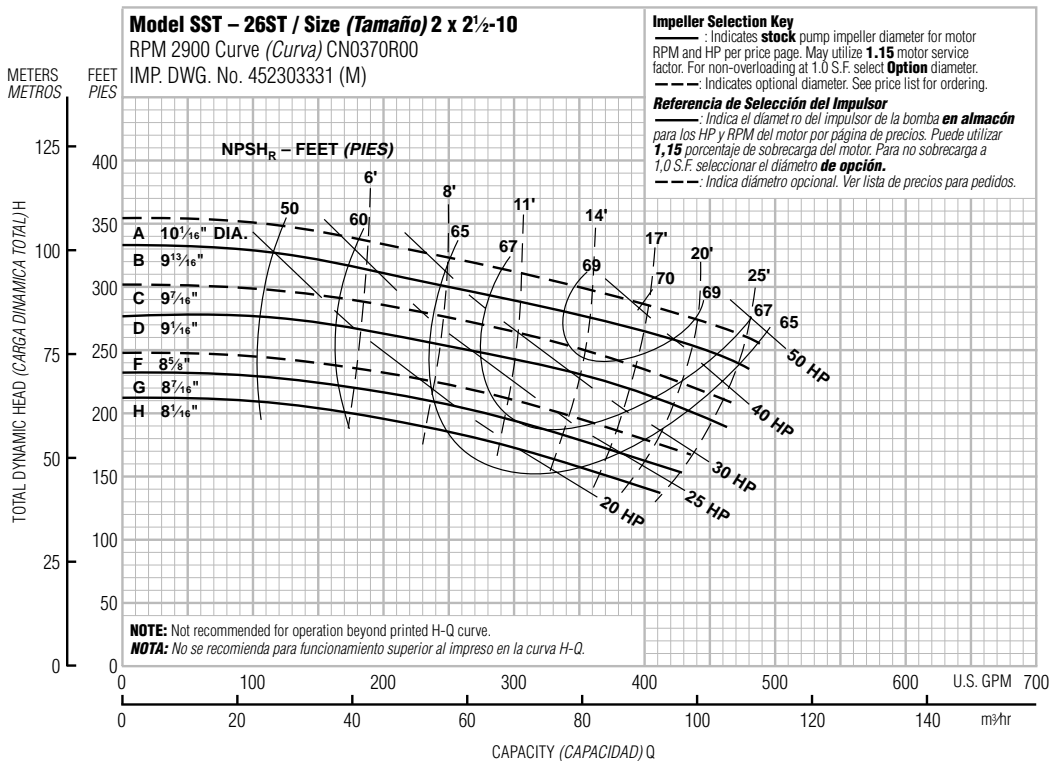

Optional Impeller, Impulsor Opcional		
Ordering Code, Código de Pedido	Standard HP Rating, Estándar HP Potencia	Dia.
A	50	10 ¹ / ₁₆ "
B	40	9 ¹³ / ₁₆ "
C	40	9 ⁷ / ₁₆ "
D	30	9 ¹ / ₁₆ "
F	30	8 ⁵ / ₈ "
G	25	8 ⁷ / ₁₆ "
H	20	8 ¹ / ₁₆ "

NOTE: Pump will pass a sphere to 1/2" diameter.

NOTA: La bomba pasará una esfera a 1/2" diámetro.

Performance Curves – 50 Hz, 2900 RPM

Curvas de Funcionamiento – 50 Hz, 2900 RPM

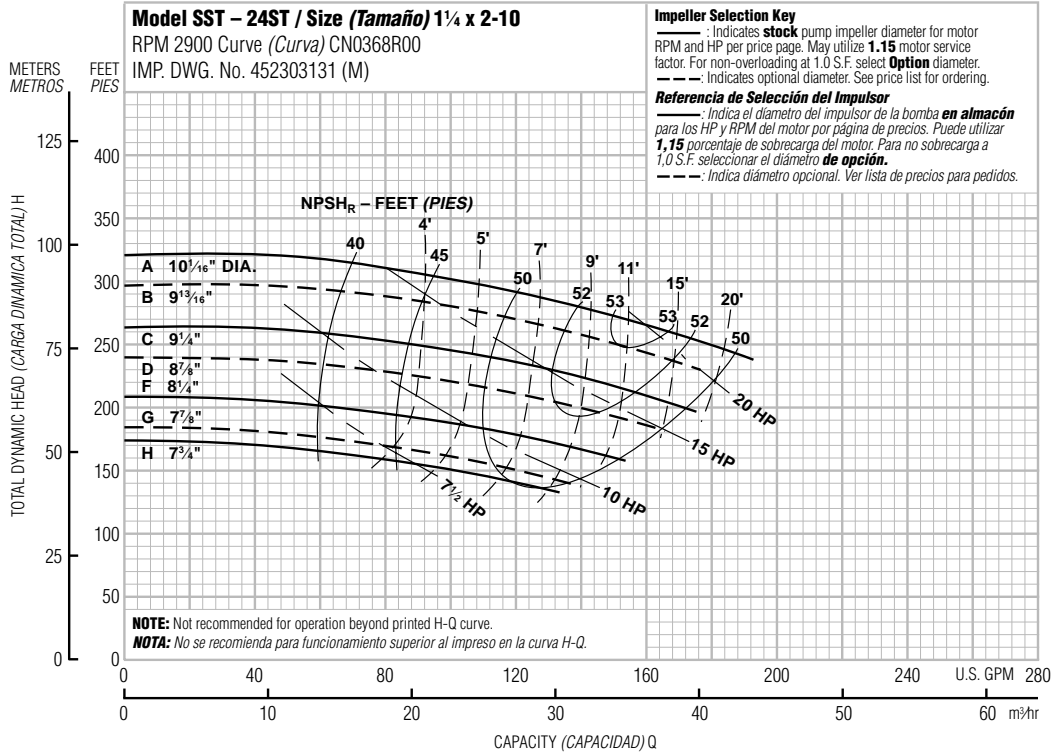

Optional Impeller, Impulsor Opcional		
Ordering Code, Código de Pedido	Standard HP Rating, Estándar HP Potencia	Dia.
A	20	10 ¹ / ₁₆ "
B	20	9 ¹³ / ₁₆ "
C	15	9 ¹ / ₄ "
D	15	8 ⁷ / ₈ "
F	10	8 ¹ / ₄ "
G	10	7 ⁷ / ₈ "
H	7 ¹ / ₂	7 ³ / ₄ "

NOTE: Pump will pass a sphere to 5/32" diameter.

NOTA: La bomba pasará una esfera a 5/32" diámetro.

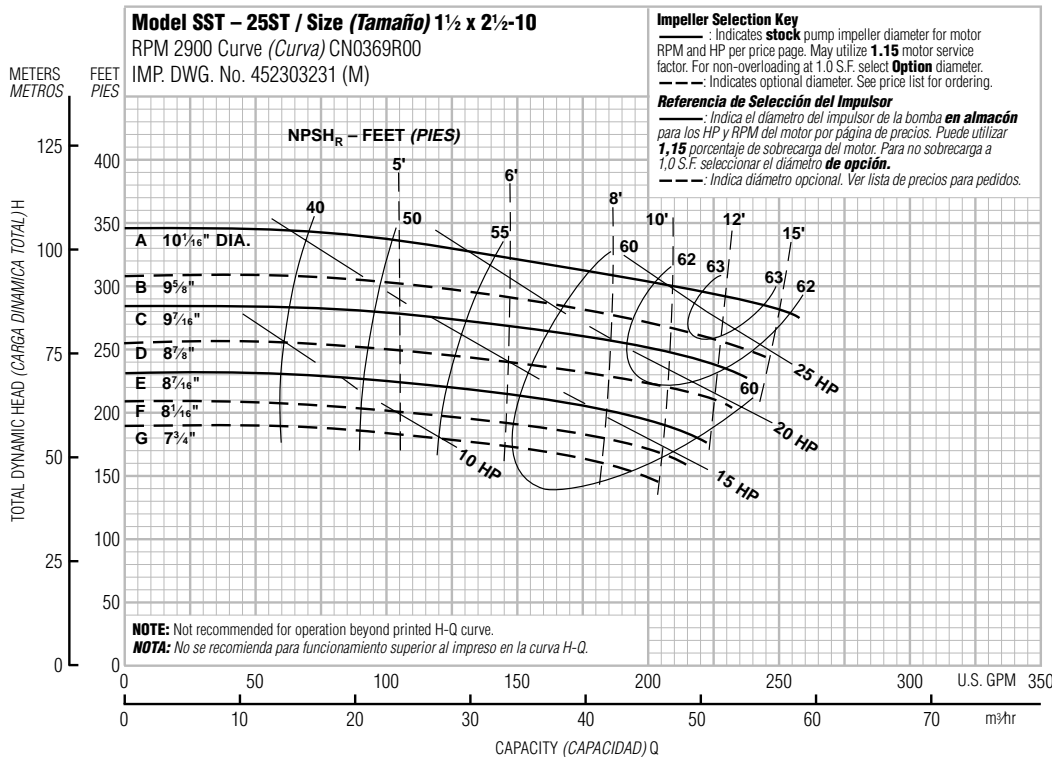

Optional Impeller, Impulsor Opcional		
Ordering Code, Código de Pedido	Standard HP Rating, Estándar HP Potencia	Dia.
A	25	10 ¹ / ₁₆ "
B	25	9 ⁵ / ₈ "
C	20	9 ⁷ / ₁₆ "
D	20	8 ⁷ / ₈ "
E	15	8 ⁷ / ₁₆ "
F	15	8 ¹ / ₁₆ "
G	15	7 ³ / ₄ "

NOTE: Pump will pass a sphere to 5/16" diameter.

NOTA: La bomba pasará una esfera a 5/16" diámetro.

Performance Curves – 50 Hz, 2900 RPM
Curvas de Funcionamiento – 50 Hz, 2900 RPM

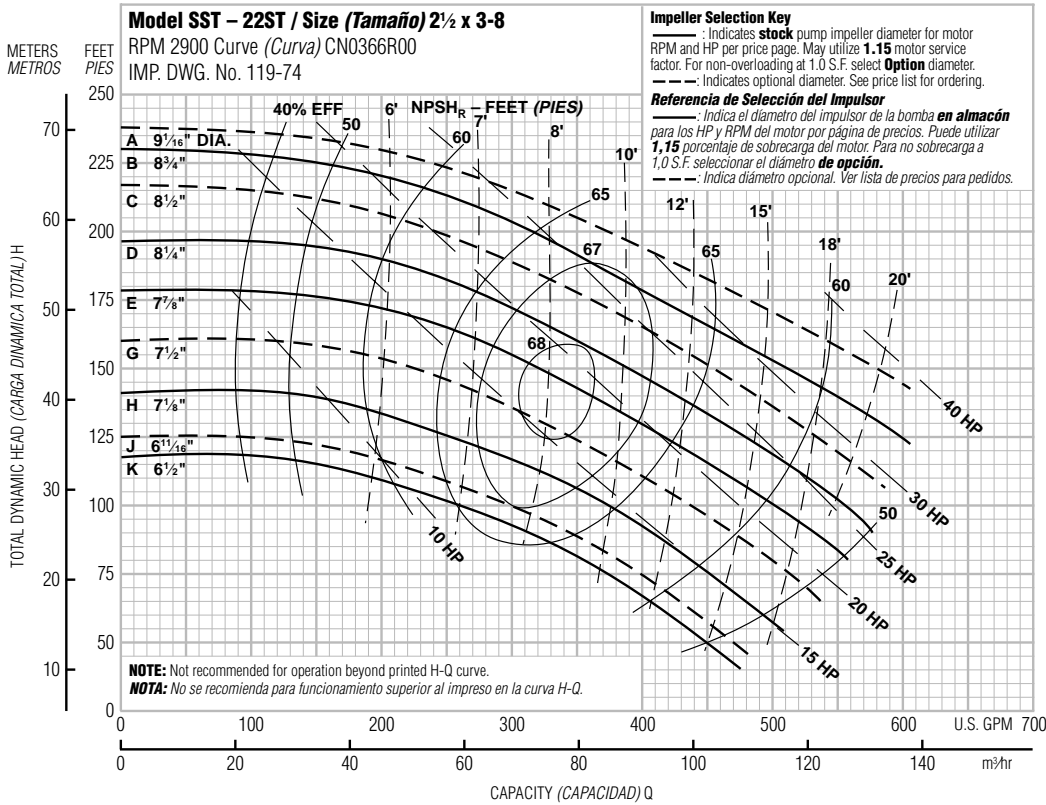

Optional Impeller, Impulsor Opcional

Ordering Code, Código de Pedido	Standard HP Rating, Estándar HP Potencia	Dia.
A	40	9 1/16"
B	30	8 3/4"
C	30	8 1/2"
D	25	8 1/4"
E	20	7 7/8"
G	20	7 1/2"
H	15	7 1/8"
J	15	6 1 1/16"
K	15	6 1/2"

NOTE: Pump will pass a sphere to 19/32" diameter.

NOTA: La bomba pasará una esfera a 19/32" diámetro.

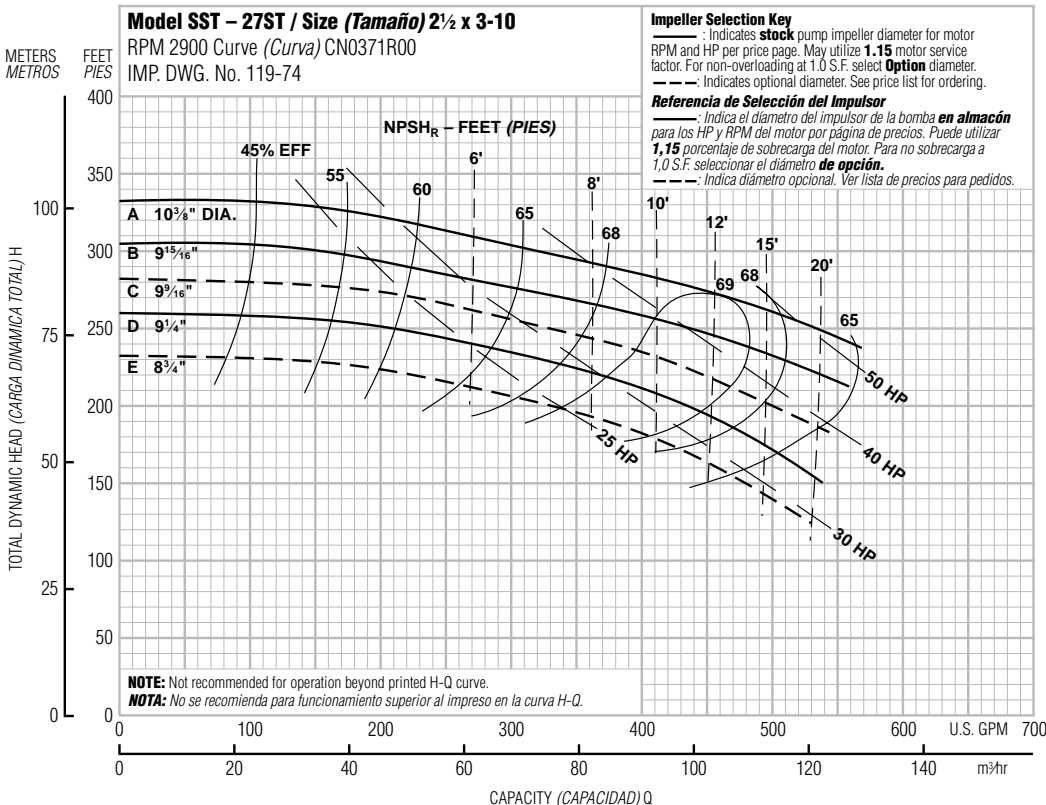

Optional Impeller, Impulsor Opcional

Ordering Code, Código de Pedido	Standard HP Rating, Estándar HP Potencia	Dia.
A	50	10 3/8"
B	40	9 15/16"
C	40	9 9/16"
D	30	9 1/4"
E	30	8 3/4"

NOTE: Pump will pass a sphere to 19/32" diameter.

NOTA: La bomba pasará una esfera a 19/32" diámetro.

Performance Curves – 50 Hz, 2900 RPM

Curvas de Funcionamiento – 50 Hz, 2900 RPM

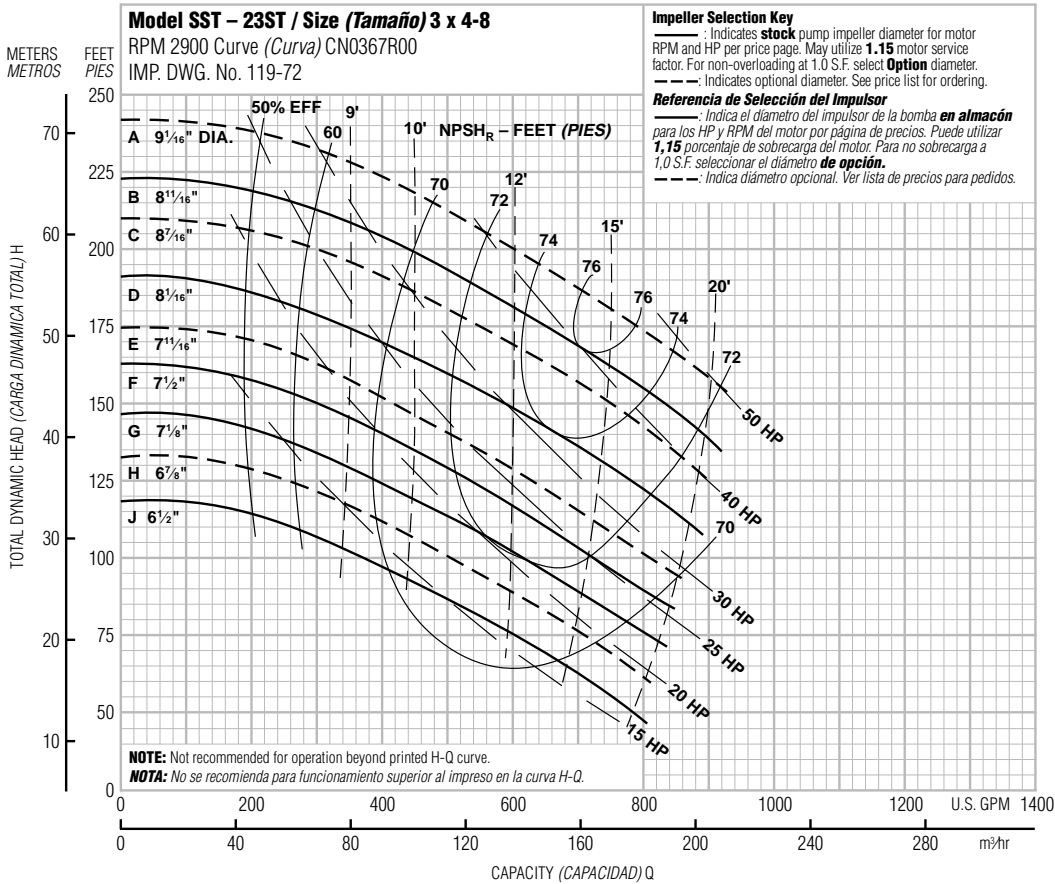

Optional Impeller, Impulsor Opcional		
Ordering Code, Código de Pedido	Standard HP Rating, Estándar HP Potencia	Dia.
A	50	9 ¹ / ₁₆ "
B	40	8 ¹ / ₁₆ "
C	40	8 ⁷ / ₁₆ "
D	30	8 ¹ / ₁₆ "
E	30	7 ¹ / ₁₆ "
F	25	7 ¹ / ₂ "
G	20	7 ¹ / ₈ "
H	20	6 ⁷ / ₈ "
J	15	6 ¹ / ₂ "

NOTE: Pump will pass a sphere to 3/4" diameter.

NOTA: La bomba pasará una esfera a 3/4" diámetro.

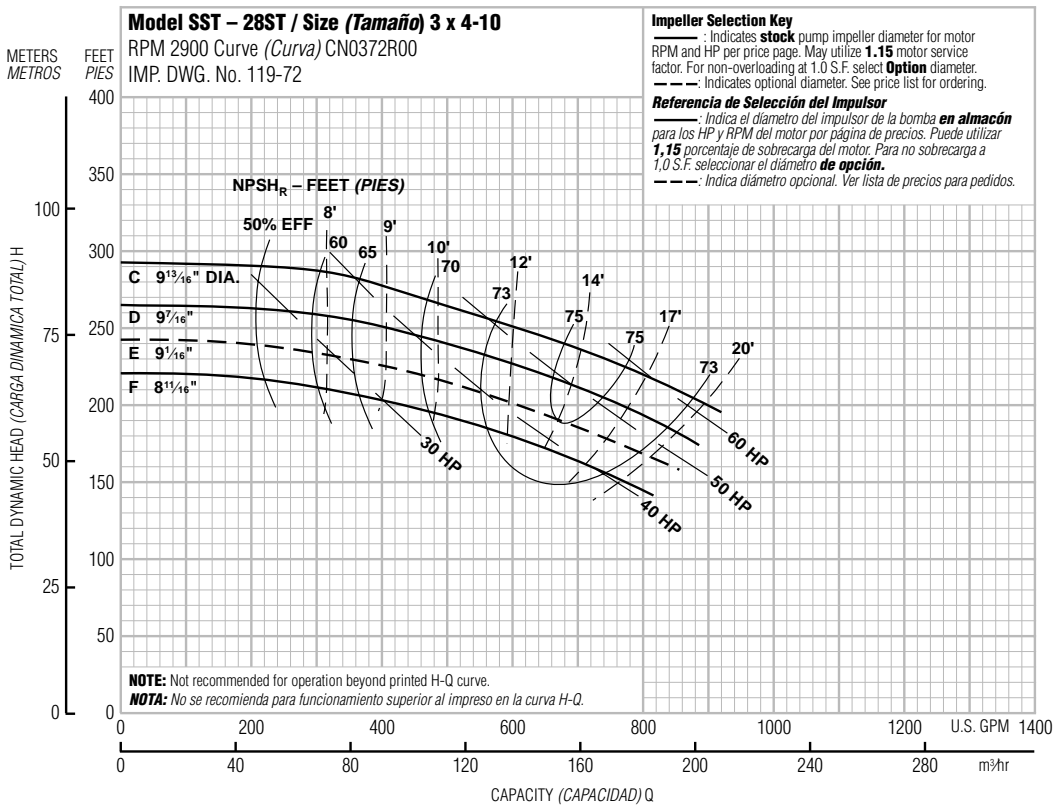

Optional Impeller, Impulsor Opcional		
Ordering Code, Código de Pedido	Standard HP Rating, Estándar HP Potencia	Dia.
C	60	9 ¹³ / ₁₆ "
D	50	9 ⁷ / ₁₆ "
E	50	9 ¹ / ₁₆ "
F	40	8 ¹ / ₁₆ "

NOTE: Pump will pass a sphere to 19/32" diameter.

NOTA: La bomba pasará una esfera a 19/32" diámetro.

SST Close Coupled – Materials of Construction
SST Acople Cerrado – Materiales de Construcción

SST Frame Mounted – Materials of Construction
SST Armazón Montado – Materiales de Construcción

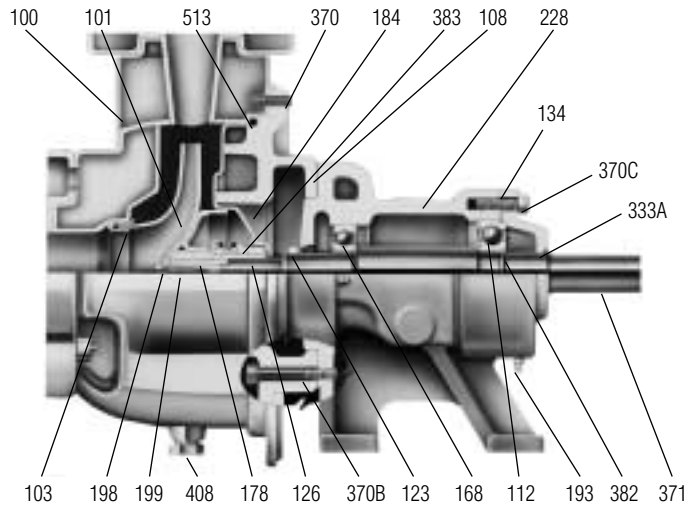
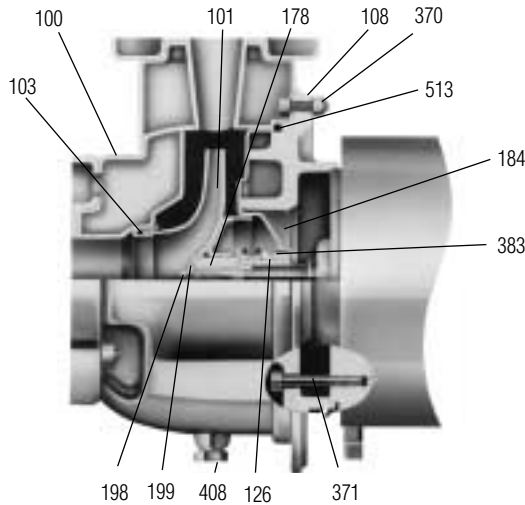

Item No., Parte No.	Description, Descripción	Materials, Materiales
100	Casing, <i>Carcasa</i>	
101	Impeller, <i>Impulsor</i>	
103	Wear ring, <i>Anillo de desgaste</i>	
184	Seal housing, <i>Alojamiento del sello</i>	
126	Shaft sleeve, <i>Camisa del eje</i>	AISI 300 series SS, AISI 300 series acero inoxidable
178	Impeller key, <i>Llave del impulsor</i>	
198	Impeller bolt, <i>Tornillo del impulsor</i>	
199	Impeller washer, <i>Arandela del impulsor</i>	
370	Casing bolt with nut (casing to adapter), <i>Tornillo de la carcasa con tuerca (carcasa para adaptador)</i>	
108	Adapter, <i>Adaptador</i>	Cast iron ASTM A48 CL20, Hierro fundido ASTM A48CL20
371	Hex head cap screw (adapter to motor), <i>Tornillo de cabeza hexagonal (adaptador para motor)</i>	Steel SAE 1200 series, Acero SAE series 1200
513	O-ring, <i>Anillo 'O'</i>	BUNA-N
408	Drain plug – 3/8 NPT, <i>Válvula de drenaje – 3/8 NPT</i>	AISI 304 SS, AISI 304 acero inoxidable
383	Mechanical seal, <i>Sello mecánico</i>	See seal chart, Ver tabla del sello

Item No., Parte No.	Description, Descripción	Materials, Materiales
100	Casing, <i>Carcasa</i>	
101	Impeller, <i>Impulsor</i>	
103	Wear ring, <i>Anillo de desgaste</i>	
184	Seal housing, <i>Alojamiento del sello</i>	
126	Shaft sleeve, <i>Camisa del eje</i>	AISI 300 series SS, AISI 300 series acero inoxidable
178	Impeller key, <i>Llave del impulsor</i>	
198	Impeller bolt, <i>Tornillo del impulsor</i>	
199	Impeller washer, <i>Arandela del impulsor</i>	
370	Casing bolt with nut, <i>Tornillo de la carcasa con tuerca</i>	
408	Drain plug – 3/8 NPT, <i>Válvula de drenaje – 3/8 NPT</i>	
513	O-ring, <i>Anillo 'O'</i>	BUNA-N
383	Mechanical seal, standard part No. 10K16, <i>Sello mecánico, parte estándar Número 10K16</i>	Carbon/ceramic BUNA-N elastomers 300 SS metal parts, Carbón/cerámica elastómeros BUNA-N partes metálicas 300 SS
108	Adapter, <i>Adaptador</i>	Cast iron ASTM A48CL20, Hierro fundido ASTM A48CL20
228	Bearing frame, <i>Armazón de balineras</i>	
134	Bearing cover, <i>Cubierta de balineras</i>	
122	Pump shaft, <i>Eje de la bomba</i>	AISI 300 series SS, AISI 300 series acero inoxidable
168	Ball bearing (inboard), <i>Balineras de bolas (interior)</i>	
112	Ball bearing (outboard), <i>Balineras de bolas (exterior)</i>	
382	Retaining ring, <i>Anillo de sujeción</i>	
370B	Hex head cap screw (adapter to bearing frame), <i>Tornillo de cabeza hexagonal (adaptador para armazón de balineras)</i>	Steel, <i>Acero</i>
370C	Hex head cap screw (bearing frame to cover), <i>Tornillo de cabeza hexagonal (armazón de balineras para cubierta)</i>	
333A	Lip seal, <i>Sello cubierto</i>	BUNA-N
193	Grease fitting, <i>Accesorio de grasa</i>	Steel, <i>Acero</i>
123	V-ring deflector, <i>Deflector anillo 'V'</i>	BUNA-N

Mechanical Seal, Sello Mecánico

John Crane Type 21 Mechanical Seal, Sello Mecánico John Crane Tipo 21							
Item, Parte	Part No., Pieza Número		Rotary, Rotativo	Stationary, Estacionario	Elastomers, Elastómeros	Metal Parts, Partes Metálicas	Intended Duty, Servicio Propuesto
	180-210 Frames, Armazones	250-360 Frames, Armazones					
383 Options, 383 Opciones	10K13	10K16	Carbon	Ceramic	BUNA	316 SS, 316 Acero inoxidable	Standard
	10K19	10K20		Ni-Resist	EPR		Hi-Temp.
	10K25	10K26		Ceramic	Viton		Mild Abrasive
	10K27	10K45		Tung. Carb.			

Channel Steel Bedplate, Clockwise Rotation Viewed from Drive End;
Fundación de Acero, Rotación en Dirección de las Aguas del Reloj Visto desde el Extremo del Motor

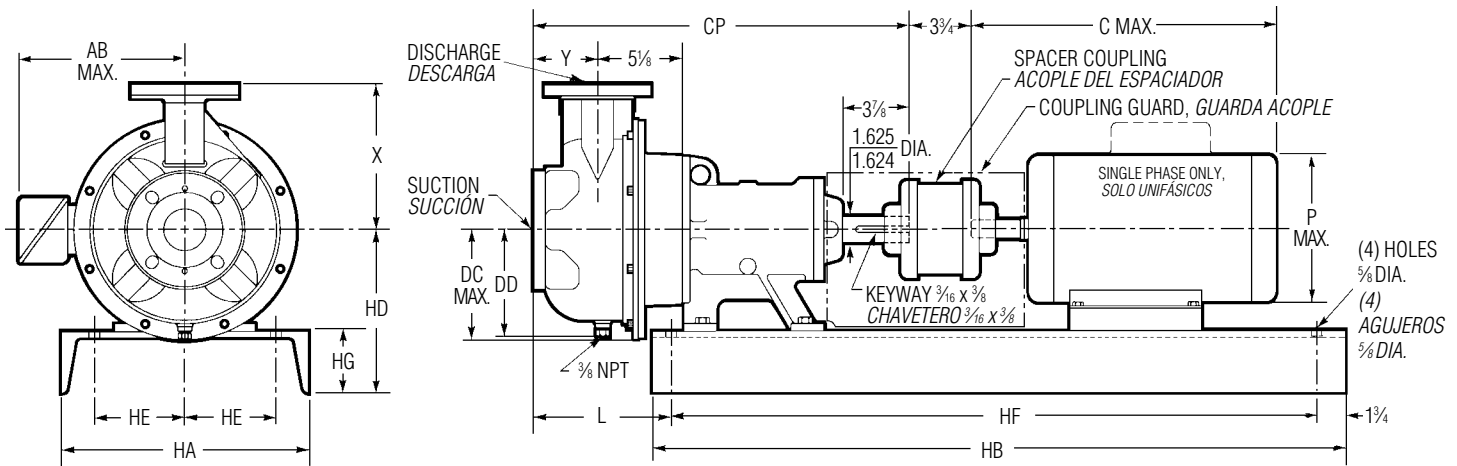

Dimensions and Weights – Determined by Pump,
Dimensiones y Pesos – Determinados por la Bomba

Pump Size, Tamaño de la Bomba	Suction*, Succión*	Discharge*, Descarga*	CP	DC Max., DC Máx.	DD	L	X	Y	Wt. (lbs.), Peso (libras)
1¼ x 2-10	2	1¼	23	6⅞	6⅞	10½	8⅛	4	125
1½ x 2 ½-10	2½	1½		6⅞	5⅞		7⅛		125
2 x 2½-8		2		6⅞	6⅞		8⅛		120
2 x 2½-10	3	2½		6⅞	5⅞	9⅛	125		
2½ x 3-8				6⅞	6⅞		8⅛		125
2½ x 3-10	4	3	24	6⅞	6⅞	11½	9⅛	5	134
3 x 4-8				7⅞	7⅞	11½	11⅞		136
3 x 4-10				7⅞	7⅞	11½	11⅞		148

NOTE:
 All pumps shipped in vertical discharge position. May be rotated in 90° increments. Tighten ⅜ – 16 casing bolts to 15 ft./lbs. torque. ½ – 13 bolts to 30 ft./lbs.

NOTA:
 Todas las bombas transportadas en posición de descarga vertical. Pueden rotarse en aumentos de 90°. Apretar ⅜ – 16 tornillos de carcasa a 15 pies/libras potencia. ½ – 13 tuercas a 30 pies/libras.

* For use with ANSI class 150 mating flanges.
 * Para usar con bridas que casan ANSI clase 150.

Available Motor and Bedplate Dimensions and Weights,
Pesos y Dimensiones Disponibles de la Fundación y del Motor

Motor Frame, Armazón del Motor	HP @ 3500 RPM		HP @ 1750 RPM – T-Frame Only				AB Max., AB Máx.	C Max., C Máx.	P Max., P Máx.	Wt. Max., Peso Máx.	Bedplate Data, Datos de la Fundación						
	Three Phase, Trifásicos		Single Phase, Monofásicos		Three Phase, Trifásicos						HA	HB	HD	HE	HF	HG	Wt. (lbs.), Peso (libras)
	ODP	TEFC	ODP	TEFC	ODP	TEFC											
184T			3 or 5	3	5	5	5⅞	18⅞	7⅞	95	13	42	10¼	5¼	38½	4	111
213T					7½	7½	7⅞	18	9⅞	116							
215T	15				10	10	9⅞	19⅞	13	136							
254T	20	15			15	15	9½	21⅞	13	266							
256T	25	20			20	20	9½	23⅞	13	264							
284TS/T	30	25			25	25	12⅞	24⅞	15	392	15	44	10½	5¾	40½	3½	124
286TS/T	40	30					12⅞	26⅞	15	422							
324TS/T	50	40					14⅞	28¾	17⅞	592	18	48	12	7¼	44½	4	183
326TS/T	60	50					14⅞	30¼	17⅞	634							
364TS/T	75	60					15⅞	31⅞	18⅞	834							
365TS/T	100	75					15⅞	32⅞	18⅞	1000							
405TS/T		100					18	36⅞	20⅞	1060	22	56	14	7¼	52½	4	214

Dimensions and weights vary with manufacturers. Dimensions in inches and weights in lbs.
 Dimensiones y pesos varían con los fabricantes. Dimensiones en pulgadas y pesos en libras.

SST Close Coupled – Dimensions and Weights

SST Acople Cerrado – Dimensiones y Pesos

(All dimensions in inches and weights in lbs. Do not use for construction purposes.)
 (Todas las dimensiones en pulgadas y pesos en libras. No usar para propósitos de construcción.)

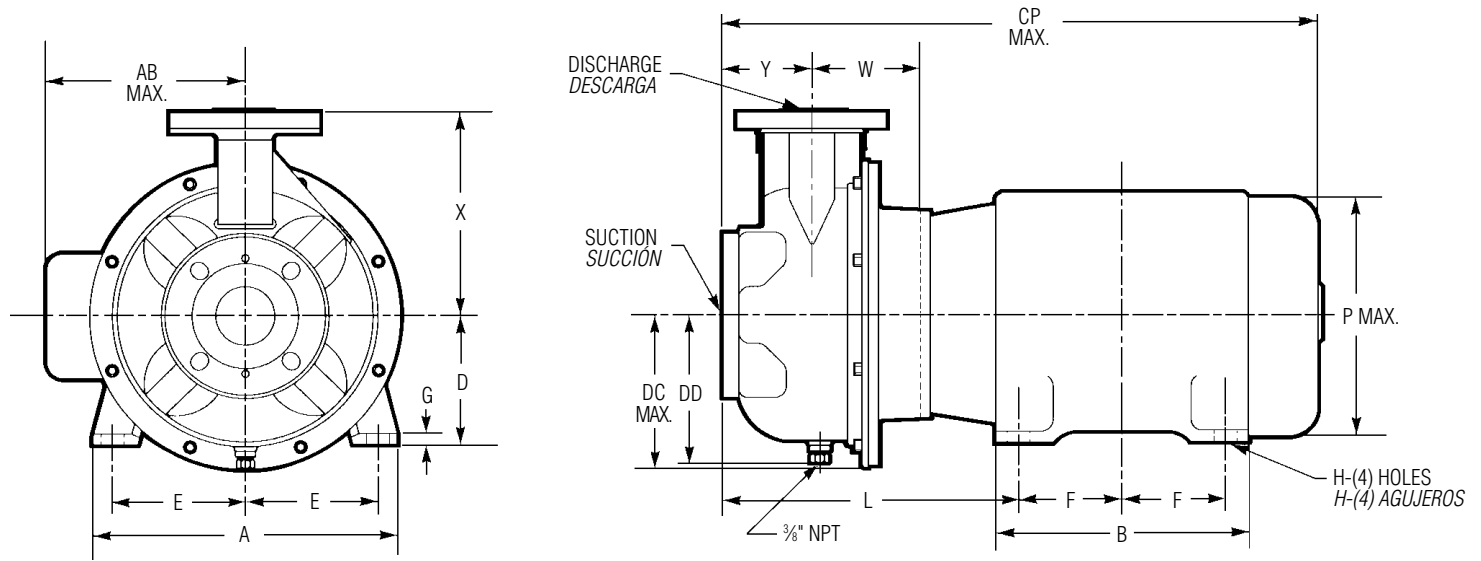

Dimensions "L" Determined by Pump and Motor, Dimensiones "L" Determinadas por la Bomba y el Motor																
Pump Size, Tamaño de la Bomba	Suction*, Succión	Disch.*, Descarga	CP Max., CP Máx.	DC Max., DC Máx.	DD	X	Y	Wt. (lbs.), Pesos (libras)	Motor Frame Size, Tamaño del Armazón del Motor							
									140	180	210	250	280	320	360	
1 1/4 x 2-10	2	1 1/4	34 1/2	6 5/8	6 5/8	8 1/16	4	75	10 1/2							
1 1/2 x 2 1/2-10	2 1/2	1 1/2		6 1/8	5 1/8	7 1/16		67	11 1/8	12 1/8	13 3/8	14 1/8				
2 x 2 1/2-8		2	6 3/8	6 3/8	8 1/16	75										
2 x 2 1/2-10			6 1/8	5 1/8	8 1/16	72										
2 1/2 x 3-8	3	2 1/2	36	6 1/8	5 1/8	9 1/16	5	84								
2 1/2 x 3-10				6 1/8	5 1/8	9 1/16		86								
3 x 4-8	4	3	37	7 5/8	7 5/8	11 1/8	5	98	12 1/8	14 1/8	14 1/8	15 1/8	16			
3 x 4-10																

* For use with ANSI class 150 mating flanges.
 * Para usar con bridas que casan ANSI clase 150.

NOTES:

1. Pumps shipped in vertical discharge as standard. For other orientations, remove casing bolts, rotate discharge to desired position, and tighten 3/8" – 16 bolts to 15 ft./lbs., 1/2" – 13 bolts to 35 ft./lbs.
2. ALL dimensions in inches.
3. Not for construction purposes.

NOTAS:

1. Las bombas se transportarán en descarga vertical como estándar. Para otras orientaciones, retirar los tornillos de la carcasa, rotar la descarga a la posición deseada, y apretar 3/8" – 16 tornillos a 15 pies/libras, 1/2" – 13 tornillos a 35 pies/libras.
2. TODAS las dimensiones en pulgadas.
3. No para propósitos de construcción.

Dimensions Determined by JM Motor Frame, Dimensiones Determinadas por el Armazón del Motor JM

Frame, Armazón	A	AB	B	D	E	F	G	H	P Max., P Máx.	W
145JM	6 1/2	5 1/4	6	3 1/2	2 3/4	2 1/2	1/8	1 1/32	6 5/8	3 5/8
182JM	8 1/2	5 7/8	6 1/2	4 1/2	3 3/4	2 1/4	3/16	1 3/32	7 7/8	
184JM						2 3/4				
213JM	9 1/2	7 3/8	8	5 1/4	4 1/4	3 1/2	7/32	1 1/16	9 5/8	
215JM										
254JM	11 1/4	9	11 3/4	6 1/4	5	4 1/8	1/4	1 7/32	11 1/2	5 1/8
256JM						5				
284JM	12 1/4	12 1/4	12 1/4	7	5 1/2	4 3/4	5/16	2 1/32	13 1/4	
286JM						5 1/2				
324JM	14	13 3/4	14	8	6 1/4	5 1/4	1	2 1/32	15 1/8	
326JM						5 1/2				
364TCZ	17 3/4	15 1/2	15 1/2	9	7	5 5/8	1	2 1/32	19	
365TCZ						6 1/8				

364TCZ and 365TCZ frames are built with 326JM shaft extensions.
 Dimensions may vary with manufacturer.
 Los armazones 364TCZ y 365TCZ se construyen con extensiones del eje 326JM.
 Las dimensiones puede que varíen con los fabricantes.

Motor Frame Selections, Selecciones del Armazón del Motor

Frame, Armazón	Motor Horsepower, Potencia del Motor						Wt. Max., Peso Máx.
	3500 RPM		1750 RPM				
	3 PH, Trifásicos		1 PH, Monofásicos		3 PH, Trifásicos		
	ODP	TEFC	ODP	TEFC	ODP	TEFC	
145JM	–	–	–	–	2	2	57
182JM	–	–	2	2-3	3	3	77
184JM	–	–	3	–	5	5	97
213JM	–	–	5	–	7 1/2	7 1/2	122
215JM	15	–	–	–	10	10	155
254JM	20	15	–	–	15	15	265
256JM	25	20	–	–	20	20	320
284JM	30	25	–	–	25	25	419
286JM	40	30	–	–	–	–	422
324JM	50	40	–	–	–	–	562
326JM	60	50	–	–	–	–	625
364TCZ	75	60	–	–	–	–	775
365TCZ	100	100, 75	–	–	–	–	905

364TCZ and 365TCZ frames are built with 326JM shaft extensions.
 Los armazones 364TCZ y 365TCZ se construyen con extensiones del eje 326JM.

SST Frame Mounted – Dimensions and Weights
SST Armazón Montado – Dimensiones y Pesos

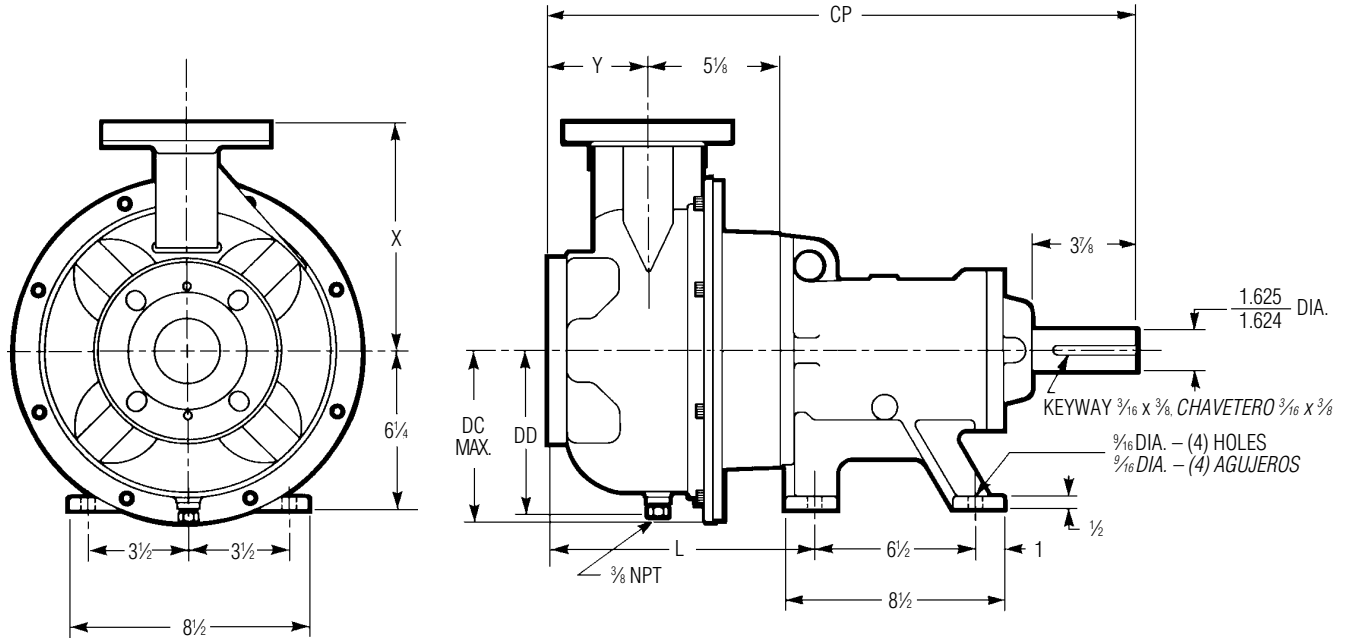

Dimensions and Weights – Bare Pump Only,
Dimensiones y Pesos – Solamente Bomba

Pump Size, Tamaño de la Bomba	Suction*, Succión*	Discharge*, Descarga*	CP	DC Max., DC Máx.	DD	L	X	Y	Wt. (lbs.), Peso (libras)		
1 1/4 x 2-10	2	1 1/4	23	6 7/8	6 5/8	10 1/8	8 15/16	4	125		
1 1/2 x 2 1/2-10	2 1/2	1 1/2		6 7/8	5 7/8		7 15/16		125		
2 x 2 1/2-8		2		6 7/8	6 5/8		8 15/16		125		
2 x 2 1/2-10		6 7/8		5 7/8	8 15/16		125				
2 1/2 x 3-8	3	2 1/2		24	6 7/8		6 5/8		11 1/8	9 15/16	134
2 1/2 x 3-10										11 1/8	136
3 x 4-8	4	3	24	7 7/8	7 3/8	11 1/8	11 1/8	148			
3 x 4-10							11 1/8	148			

* For use with ANSI class 150 mating flanges.
 * Para usar con bridas que casan ANSI clase 150.

NOTES:

1. Pumps will be shipped with top vertical discharge as standard. For other orientations, remove casing bolts, rotate discharge to desired position, and tighten 3/8-16 bolts to 15 ft./lbs., 1/2-13 bolts to 35 ft./lbs.
2. ALL dimensions in inches.
3. Not for construction purposes.

NOTAS:

1. Las bombas se transportarán con la descarga vertical superior como estándar. Para otras orientaciones, retirar los tornillos de la carcasa, rotar la descarga a la posición deseada, y apretar 3/8-16 tornillos a 15 pies/libras, 1/2-13 tornillos a 35 pies/libras.
2. TODAS las dimensiones en pulgadas.
3. No para propósitos de construcción.

Specifications Especificaciones

Capacities to:

1100 GPM (250 m³/hr) at 3500 RPM
775 GPM (177 m³/hr) at 1750 RPM

Heads to:

520 feet THD (158 m) at 3500 RPM
130 feet THD (40 m) at 1750 RPM

Maximum working pressures to:

230 PSI (15 bars)
Maximum temperatures to:
212°F (100°C) with standard seal or
250°F (121°C) with optional high
temperature seal.

All wetted components of AISI:

Type 304 stainless steel material.

Rotation:

Clockwise when viewed
from motor end.

Enclosed impeller and replaceable wear ring:

for high efficiency and maximum
wear life.

Motor (close coupled):

NEMA standard JM shaft open
drip-proof, totally enclosed and
explosion-proof enclosures, 60 Hz,
1750 or 3500 RPM.
Single phase ODP (115/230 V)
1750 RPM, 2 – 5 HP.

Three phase ODP. TEFC/Exp. proof
(208 – 230/460 V).
3500 RPM, 15 – 100 HP
1750 RPM, 2 – 75 HP

NOTE: Overload protection must be
provided. Contactor with overload for
single phase or starter with heaters
for three phase ordered separately.

Motor (frame mounted):

NEMA standard T-frame open
drip-proof, totally enclosed and
explosion-proof (three phase only)
enclosures 60 Hz, 1750 or 3500
RPM.

Single phase (115/230 V)
1750 RPM, 3 – 5 HP

Three phase (208 – 230/460 V)
3500 RPM, 15 – 100 HP
1750 RPM, 5 – 70 HP

NOTE: Overload protection must be
provided. Contactor with overload for
single phase or starter with heaters
for three phase ordered separately.

Optional: Rigid carbon steel
bedplate, sheet metal coupling guard
designed to OSHA specifications and
T.B. WOODS type "SC" spacer
couplings.

Capacidades:

1100 GPM (250 m³/hr) a 3500 RPM
775 GPM (177 m³/hr) a 1750 RPM

Cargas:

520 pies THD (158 m) a 3500 RPM
130 pies THD (40 m) a 1750 RPM

Presión de trabajo máxima:

230 PSI (15 baras)

Temperatura máxima:

212°F (100°C) con sello estándar o
250°F (121°C) con sello opcional
para alta temperatura.

**Todos los componentes
mojados de AISI:** Material de
acero inoxidable tipo 304.

Rotación: En dirección de las
agujas del reloj visto desde el
extremo final del motor.

**Impulsor encerrado y anillo de
desgaste reemplazable:** para
alta eficiencia y máxima durabilidad.

Motor (acople cerrado): Eje a
prueba de goteo JM estándar NEMA,
totalmente encerrado y recintos a
prueba de explosión, 60 Hz, 1750 ó
3500 RPM.

Unifásicos ODP (115/230 V)
1750 RPM, 2 – 5 HP

Trifásicos ODP. TEFC/a prueba de
explosión (208 – 230/460 V).
3500 RPM, 15 – 100 HP
1750 RPM, 2 – 75 HP

NOTA: Se debe de proporcionar
protección térmica contra
sobrecarga. Contactor con
protección térmica contra sobrecarga
para unifásicos o arrancadores con
calentadores para trifásicos se piden
por separado.

Motor (armazón montado):

Armazón abierto T a prueba de goteo
estándar NEMA, totalmente
encerrado y recintos a prueba de
explosión (trifásicos solamente)
60 Hz, 1750 ó 3500 RPM.

Unifásicos (115/230 V)
1750 RPM, 3 – 5 HP.
Trifásicos (208 – 230/460 V)
3500 RPM, 15 – 100 HP
1750 RPM, 5 – 70 HP

NOTA: Se debe de proporcionar
protección térmica contra
sobrecarga. Contactor con
protección térmica contra sobrecarga
para unifásicos o arrancadores con
calentadores para trifásicos se piden
por separado.

Opcional: Fundación rígida de
acero al carbono, guarda acople de
metal laminado diseñado según las
especificaciones OSHA y acoples del
espaciador T.B. WOODS tipo "SC".

Typical Applications Aplicaciones Típicas

Specifically designed for all
traditional cast iron or bronze fitted
water and low grade corrosive
services.

- Water circulation
- Booster systems
- Liquid transfer
- HVAC pump replacements
- General service pumping

*Diseñada específicamente para todos
los servicios de agua de hierro
fundido o recubiertas de bronce y
servicios corrosivos de bajo grado.*

- *Circulación de Agua*
- *Aumento de presión*
- *Transferencia de líquidos*
- *Reemplazos para bombas HVAC*
- *Bombeo de servicios generales*



**HVAC,
Calefacción,
Ventilación y Aire
Acondicionado**



**Tubing washer,
Arandela de
tubería**



**Water truck,
Camión cisterna**